

Tavoli. Tables. Tische. Tables



BONALDO

Bonaldo: Ottant'anni di storia

Bonaldo: Eighty years of history
Bonaldo: Achtzig Jahre Geschichte
Bonaldo: 80 ans d'histoire

En

This story began in 1936, when Giovanni Vittorio Bonaldo started up a craft-based metal working business. During the 1950s industrial production began on bedsteads, and it was extended during the '60s to iron beds. An extraordinary intuition led to the production of a folding bedstead, which went on to become a market standard, and which is still extraordinary today, considering its future implications.

The company subsequently specialised in the processing of tubular metal and invested in new machinery and technology, choices which allowed it to extend its range of products and to implement machining processes at the very cutting edge.

Today, Bonaldo designs, produces and distributes design-oriented tables, chairs, sofas, beds and interior furnishings for the Italian and the international market.

De

Diese Geschichte beginnt im Jahr 1936, als Giovanni Vittorio Bonaldo einen Handwerksbetrieb für die Metallverarbeitung eröffnet. In den Fünfzigerjahren beginnt er mit der industriellen Produktion von Lattenrosten, ab den Sechzigerjahren werden auch Metallbetten produziert. Herausragend wegen der Folgen für die Zukunft bleibt noch immer die Idee, einen klappbaren Lattenrost zu entwickeln, der später auf dem Markt zum Standard wurde.

Das Unternehmen spezialisierte sich in der Folge auf die Bearbeitung von Metallrohren und investierte in neue Maschinen und Technologien, eine Entscheidung, die die Möglichkeit bot, die Produktpalette zu erweitern und immer fortschrittlichere Verfahren anzuwenden.

Heute entwirft, produziert und vertreibt Bonaldo Tische, Stühle, Sofas, Betten und designorientierte Einrichtungsgegenstände für den italienischen und den internationalen Markt.

Fr

Une histoire qui commence en 1936, lorsque Giovanni Vittorio Bonaldo démarre une entreprise artisanale spécialisée dans la transformation des métaux. À partir des années cinquante l'entreprise se lance dans la production industrielle de sommiers à lattes et, dans les années soixante, de structures de lit en fer. L'intuition – extraordinaire à en juger par ses retombées futures – de réaliser un sommier pliant devient bientôt un standard sur le marché.

L'entreprise se spécialise par la suite dans la transformation de tubes métalliques et investit pour se doter de machines et de technologies nouvelles, autant de choix qui lui permettent d'élargir sa gamme de produits et de mettre en place des processus de plus en plus évolués.

Aujourd'hui, Bonaldo conçoit, fabrique et commercialise des tables, des chaises, des canapés, des lits et des compléments design-orientés pour le marché italien et international.

Questa storia inizia nel 1936, quando Giovanni Vittorio Bonaldo apre un'attività artigianale per la lavorazione dei metalli. A partire dagli anni Cinquanta inizia una produzione industriale di reti da letto, affiancata, negli anni Sessanta, a quella dei letti in ferro. Rimane straordinaria, per le sue implicazioni future, l'intuizione di realizzare una rete pieghevole, diventata poi uno standard di mercato.

L'azienda si specializza successivamente nella lavorazione di tubolari metallici e investe in nuovi macchinari e tecnologie, scelte che le consentono di ampliare la sua gamma di prodotti e di implementare processi sempre più evoluti. Oggi Bonaldo progetta, produce e distribuisce tavoli, sedie, divani, letti e complementi design-oriented, per il mercato italiano e internazionale.

Evoluzione

Evolution / Entwicklung / Évolution

It Sono la dedizione e l'impegno di tre generazioni imprenditoriali che hanno permesso a Bonaldo di diventare un importante punto di riferimento nel settore dell'arredamento e del design. È il forte radicamento territoriale a permettere al marchio di far crescere, nei siti di Borgoricco e Villanova, vicino Padova, una squadra di maestranze che, in molti casi, si tramanda la capacità artigianale di padre in figlio.

De Die Hingabe und der Einsatz von drei Unternehmergenerationen machten aus Bonaldo einen wichtigen Bezugspunkt in der Möbel- und Designbranche. Durch die starke lokale Verwurzelung konnte das Unternehmen an den Standorten Borgoricco und Villanova, in der Nähe von Padua, eine Belegschaft aufbauen, die oft das handwerkliche Können vom Vater an den Sohn weitergibt.

En It is the dedication and commitment that have been passed down three generations of entrepreneurs that have enabled Bonaldo to become a major benchmark in the furniture and design industry. Bonaldo's strong ties to the local area have enabled the brand to grow and develop, in the Borgoricco and Villanova sites near Padua, a team of experts who, in many cases, have been craftsmen from one generation to the next.

Fr C'est la passion et l'engagement de trois générations d'entrepreneurs qui ont permis à Bonaldo de devenir une référence incontournable dans le secteur de l'ameublement et du design. Et c'est grâce à son enracinement territorial que la marque a pu développer, sur les sites de Borgoricco et Villanova près de Padoue, une équipe d'ouvriers qui transmettent souvent leurs capacités artisanales de père en fils.

Albino Bonaldo,
President

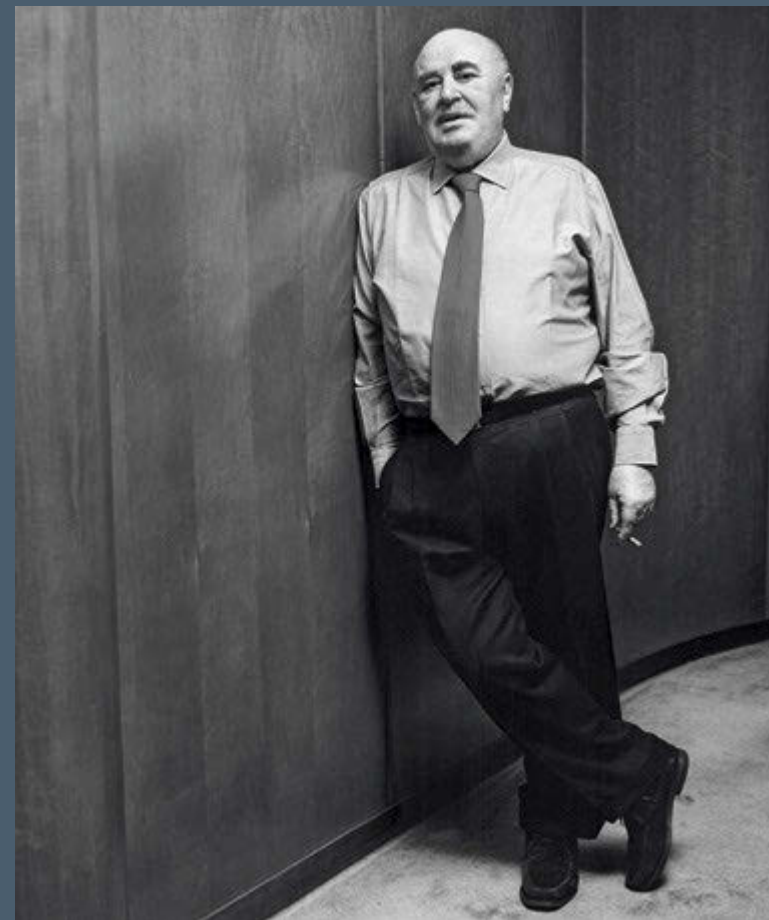

Ricerca e creazione

Research and creativity / Forschung und Kreativität / Recherche et création

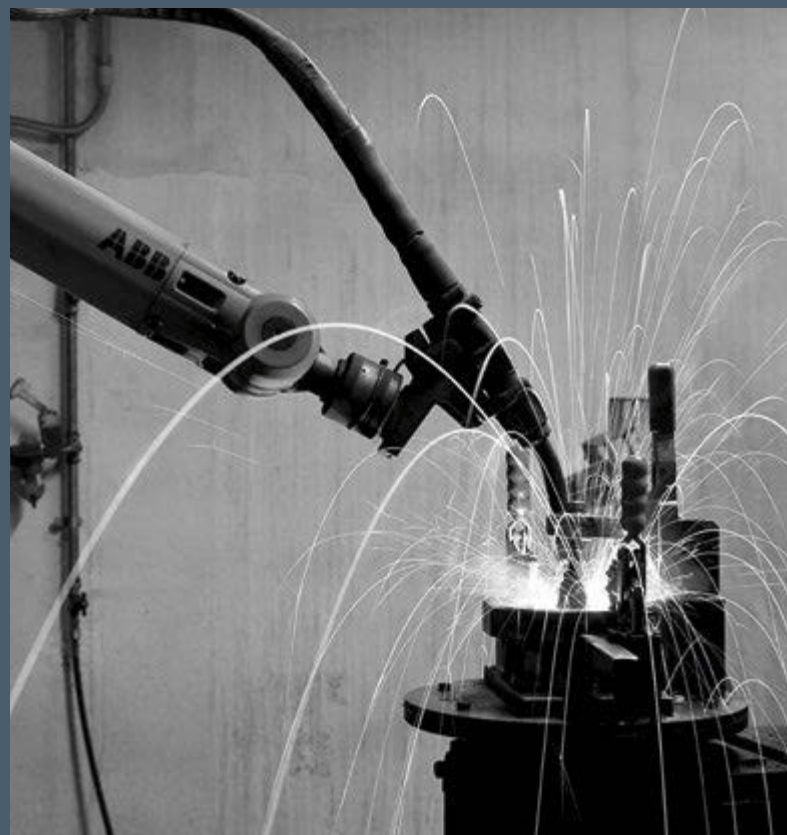

Tecnologia, manualità e organizzazione.
Conoscenze tecniche e abilità manuali rappresentano i punti di riferimento di una struttura industriale moderna e competitiva che possiede una cultura dell'oggetto fatto secondo i canoni della migliore tradizione italiana.

Technology, manual skill and organization.
Technical knowledge and manual dexterity represent the reference points for a modern and competitive industrial organization that possesses a culture of products created in line with the best principles of Italian tradition.

Technologie, Handwerk und perfekte Organisation.
Technisches Know-how und handwerkliches Geschick bilden die Eckpfeiler eines modernen, wettbewerbsfähigen Industriebetriebs, der auf Designkultur nach bester italienischer Tradition setzt.

Technologie, habileté et organisation.
Les connaissances techniques et le savoir-faire manuel représentent les points forts d'une structure industrielle moderne et compétitive qui possède une culture de l'objet réalisé selon les critères de la plus belle tradition italienne.

IT È la capacità di rimanere ancorati al Made in Italy, laddove questo si concretizza in una coerente attenzione alla scelta dei materiali, alla lavorazione in loco di ogni singolo componente, ad un processo di controllo attento e rigoroso.

È, infine, il costante investimento in Ricerca e Sviluppo che permette a Bonaldo di realizzare prodotti capaci di soddisfare le esigenze e i gusti di un pubblico dinamico ed internazionale.

En Bonaldo's ability to remain true to the spirit of excellence Made in Italy can be seen in the painstaking care with which materials are selected, the on-site processing of every single component and a strict and careful control process.

Last but not least, ongoing investments in Research and Development have enabled the Bonaldo brand to manufacture products designed to accommodate the needs and tastes of a dynamic, international target.

De Das Unternehmen ist auch im „Made in Italy“ verankert, das bedeutet großes Augenmerk für die Auswahl der Materialien, die Bearbeitung jedes einzelnen Bestandteils vor Ort und strenge und gewissenhafte Qualitätskontrollen.

Durch die ständigen Investitionen in Forschung und Entwicklung ist Bonaldo schließlich in der Lage, Produkte zu erzeugen, die den Ansprüchen und dem Geschmack eines dynamischen und internationalen Publikums entsprechen.

Fr C'est la capacité de rester fidèle au Made in Italy, fidélité qui se traduit par une attention cohérente au choix des matériaux, par la transformation sur site de chaque composant, et par un processus de contrôle attentif et rigoureux.

Ce sont enfin des investissements constants dans la Recherche et Développement qui permettent à Bonaldo de réaliser des produits capables de satisfaire les exigences et les goûts d'un public dynamique et international.

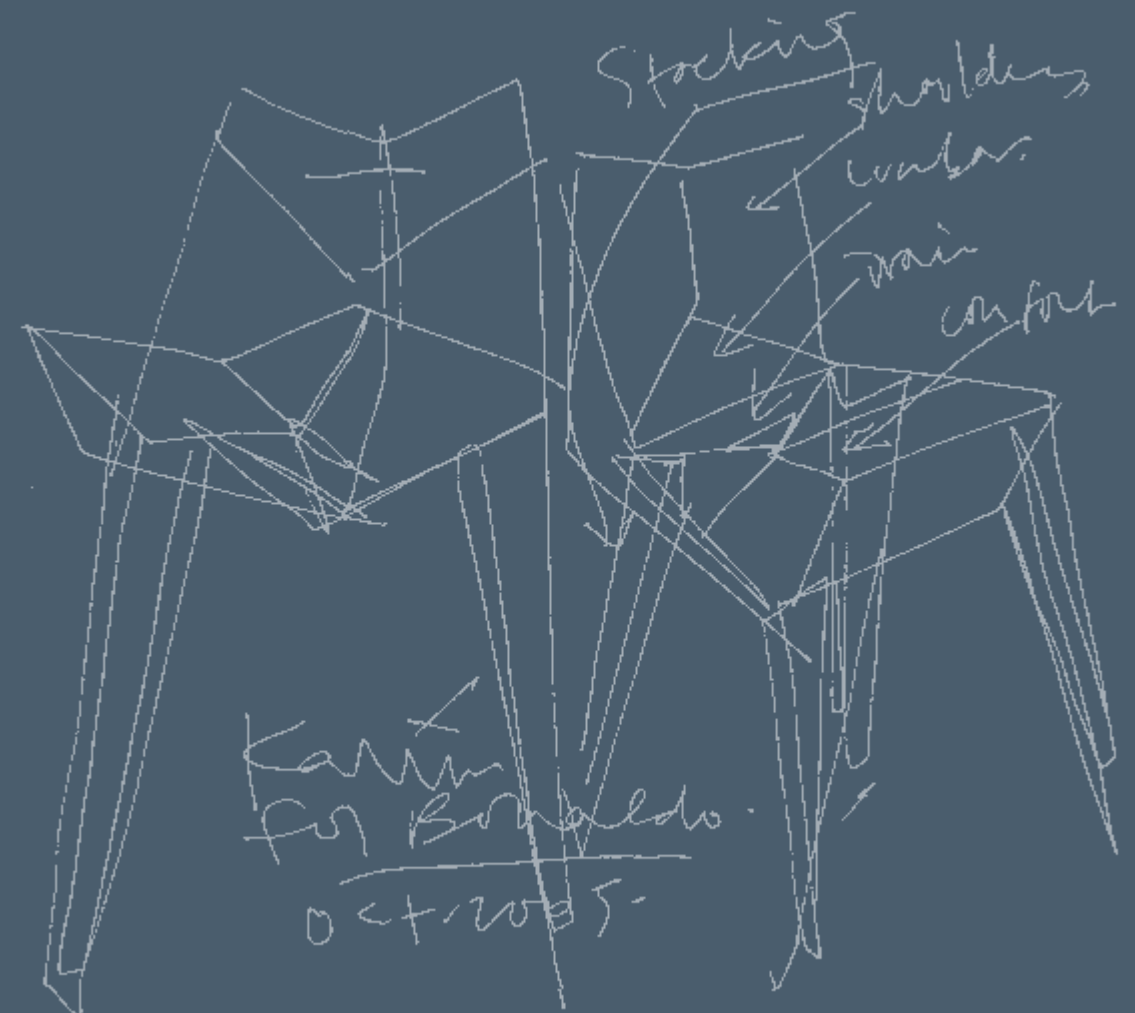

L'azienda

The company / Das Unternehmen / L'entreprise

1. UFFICI E UNITÀ PRODUTTIVA 1
Villanova di Camposampiero (PD)
16.000 mq
Ospita la produzione di tavoli e sedie

OFFICES AND PRODUCTION UNIT 1
Villanova di Camposampiero (PD)
16,000 m2
Houses the production of tables and chairs

BÜROS UND PRODUKTIONSEINHEIT 1
Villanova di Camposampiero (PD)
16.000 m²
Hier erfolgt die Produktion von Tischen und Stühlen

BUREAUX ET UNITÉ DE PRODUCTION N°1
Villanova di Camposampiero (Padoue)
16 000 m2
Production de tables et chaises

It Sono tre i luoghi della produzione nei quali il “made in Italy” Bonaldo assume corpo e sostanza. Tre strutture che assolvono il compito di dare forma tangibile ai contenuti della marca.

De In drei Produktionsstätten nehmen die Produkte “Made in Italy” von Bonaldo Körper und Gestalt an. Es gibt drei Standorte, die dem Inhalt der Marke eine greifbare Form geben.

En There are three production sites where excellence “made in Italy” by Bonaldo come to life. Three facilities which have the task of giving a tangible shape to the brand's concepts.

Fr Le Made in Italy Bonaldo prend corps dans trois sites de production, trois structures qui accomplissent la tâche de donner une forme tangible aux contenus de la marque.

2. UFFICI E UNITÀ PRODUTTIVA 2
Borgoricco (PD)
7.000 mq
Qui vengono realizzati letti e divani.

BÜROS UND PRODUKTIONSEINHEIT 2
Borgoricco (PD) 7.000 m²
Hier werden Sofas und Betten hergestellt.

OFFICES AND PRODUCTION UNIT 2
Borgoricco (PD)
7,000 m2
This is where beds and sofas are made.

BUREAUX ET UNITÉ DE PRODUCTION N°2
Borgoricco (Padoue)
7000 m²
Production de canapés et lits

3. SHOWROOM
Borgoricco (PD)
6.000 mq
Immerso nella campagna veneta, è il luogo dell'incontro, della relazione, dello scambio.

SHOWROOM
Borgoricco (PD)
6.000 m²
Ein Ort der Begegnung, der Kontakte und des Austauschs, mitten im venezianischen Hinterland.

SHOWROOM
Borgoricco (PD)
6,000 m2
Set in the Veneto countryside, it is the place for meeting, relating, exchanging.

SHOWROOM
Borgoricco (Padoue)
6000 m²
Plongé dans la campagne vénète, il est le lieu de la rencontre, de la relation et de l'échange.



Showroom



Il Good Design Award è un riconoscimento istituito dal Chicago Athenaeum, prestigioso centro culturale statunitense dedicato al design in tutte le sue accezioni e declinazioni.

The Good Design Award is a prize offered by the Chicago Athenaeum, the famous US cultural centre dedicated to design in all its meanings and applications.

Der Good Design Award ist eine Auszeichnung des Chicago Athenaeum. Das renommierte amerikanische Kulturzentrum befasst sich mit Design in allen Varianten und Ausdrucksformen.

Le Good Design Award est un prix décerné par le Chicago Athenaeum, un centre culturel étasunien de prestige consacré au design sous toutes ses formes et ses déclinaisons.

En

Following a major restyling process that involved a surface area of approximately 6,000 m², one of the former production units was turned into the new company showroom. The showroom is now a charming and disarming setting that is the perfect place to admire Bonaldo collections, from the latest new products to icons from the past.

The space, which is also used for presentations and workshops, tells the story of the brand from the onset.

The entrance to the showroom stands out for a pathway created using colour-changing stones sourced in China, the surface of which modifies at low temperatures, creating grain patterns that recall flower motifs.

Inside the showroom, two winter gardens add further charm to the setting, with lights and colours designed to beguile visitors. In 2011, the showroom project was awarded the prestigious "Good Design Award" by the Chicago Athenaeum.

De

Die frühere Produktionsstätte mit einer Fläche von circa 6.000 m² wurde in umfangreichen Renovierungsarbeiten in den Showroom des Unternehmens umgebaut.

Der Showroom ist heute ein eindrucksvoller und spannender Ort, an dem man die Bonaldo-Kollektionen bewundern kann, von den neuen Produkten bis zu den Bonaldo-Ikonen.

Der Raum, der auch für Präsentationen und Workshops genutzt wird, erzählt die Geschichte der Marke seit den Anfängen. Der Eingang zum Showroom ist mit changierenden Steinen aus China gepflastert. Bei niedrigen Temperaturen verändert sich die Oberfläche des Steins, es entsteht eine Maserung, die an Blumenmuster erinnert.

Im Inneren des Ausstellungsraumes verleihen zwei Wintergärten dem Raum noch mehr Atmosphäre, mit überraschenden Licht- und Farbeffekten. Der Entwurf wurde 2011 mit dem renommierten Preis „Good Design Award“ des Chicago Athenaeum ausgezeichnet.

Fr

Suite à une importante opération de requalification, une surface d'environ 6 000 m² d'une ancienne unité de production a pu devenir le showroom de l'entreprise.

Le showroom est maintenant un lieu magnifique où l'on peut admirer les collections Bonaldo, des dernières nouveautés aux produits phare.

L'espace, qui est également utilisé pour des présentations et des workshops, raconte l'histoire de la marque depuis ses origines.

L'entrée du showroom est caractérisée par un parcours marqué de pierres aux couleurs chatoyantes provenant de Chine et dont la surface se modifie à basse température pour créer un veinage aux motifs floraux.

À l'intérieur de l'espace d'exposition, deux jardins d'hiver apportent un charme supplémentaire avec un éclairage et des couleurs qui surprennent le visiteur. Le projet a reçu en 2011 le prestigieux prix « Good Design Award » du Chicago Athenaeum.

Dopo un importante intervento di riqualificazione, che ha coinvolto una superficie di circa 6.000 mq, una delle vecchie unità produttive è stata trasformata nello showroom aziendale. Lo showroom è ora un luogo suggestivo ed emozionante, in cui è possibile ammirare le collezioni Bonaldo, dai nuovi prodotti alle icone. Lo spazio, che viene utilizzato anche per presentazioni e workshop, racconta la storia del marchio a partire dalle origini. L'ingresso dello showroom è caratterizzato da un percorso realizzato con pietre cangianti provenienti dalla Cina, la cui superficie si modifica con le basse temperature, creando venature che ricordano motivi floreali. All'interno dello spazio espositivo due giardini d'inverno offrono ulteriore emozione allo spazio, con luci e colori che sorprendono il visitatore. Il progetto ha ricevuto nel 2011 il prestigioso riconoscimento "Good Design Award" del Chicago Athenaeum.



Architetti e Designer

Sono oltre 25 i designer e architetti italiani ed internazionali che negli anni hanno contribuito a interpretare lo stile Bonaldo, tra questi Karim Rashid, Bartoli Design, Mauro Lipparini, Toshiyuki Kita, Alain Gilles...e che hanno dato all'azienda un gusto sempre più internazionale. Sono la sensibilità e la lungimiranza a permettere all'azienda non solo di instaurare un proficuo rapporto con designer e architetti di fama mondiale, ma anche di vincere i più prestigiosi premi internazionali del settore del design.

En

Architects and Designers

Over 25 different Italian and international designers and architects have contributed over the years to interpret the Bonaldo style, including Karim Rashid, Bartoli Design, Mauro Lipparini, Toshiyuki Kita, Alain Gilles...giving the brand an increasingly international outlook. Sensitivity and forward-thinking have enabled Bonaldo not only to establish a successful partnership with world-famous designers and architects, but also to win some of the most prestigious international design awards.

De

Architekten und Designer

Über 25 italienische und internationale Designer und Architekten haben in den vergangenen Jahren den Stil von Bonaldo mitinterpretiert, unter ihnen Karim Rashid, Bartoli Design, Mauro Lipparini, Toshiyuki Kita, Alain Gilles...und sie haben dem Unternehmen eine immer internationalere Linie gegeben. Mit Feingefühl und Weitblick hat das Unternehmen nicht nur eine fruchtbare Beziehung mit Designern und Architekten von Weltruhm aufgebaut, sondern auch die renommiertesten Preise im Designbereich gewonnen.

Fr

Architectes et designers

Karim Rashid, Bartoli Design, Mauro Lipparini, Toshiyuki Kita, Alain Gilles, ce ne sont que quelques noms des plus de 25 designers et architectes italiens et internationaux qui ont contribué au fil des années à interpréter le style Bonaldo, en donnant à l'entreprise une touche toujours plus internationale; La sensibilité et la clairvoyance de l'entreprise ont permis non seulement d'instaurer un rapport fructueux avec des designers et architectes de réputation mondiale, mais aussi de remporter les prix internationaux les plus prestigieux dans le secteur du design.

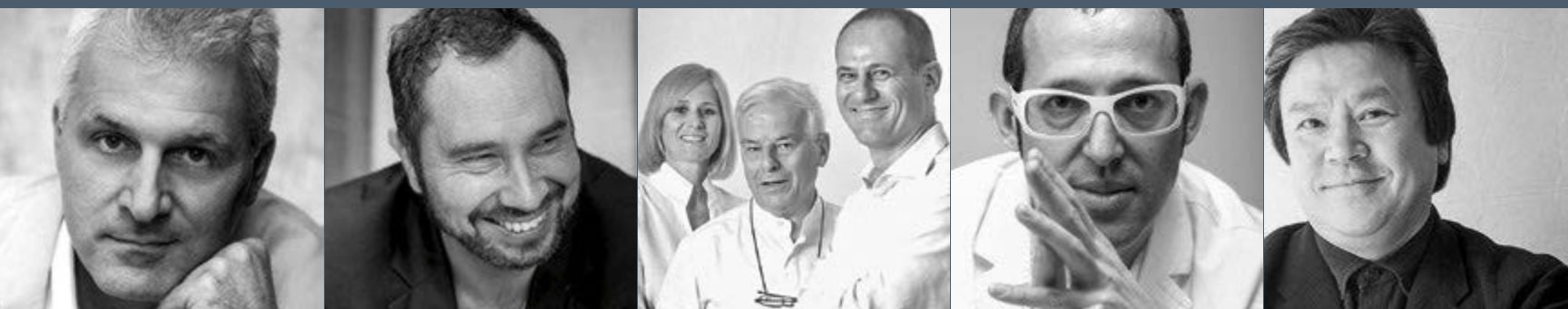

Premi

I premi ottenuti da Bonaldo in questi anni hanno sicuramente rafforzato la notorietà del brand e dei suoi prodotti, in Italia e soprattutto all'estero, dove viene rivolta molta attenzione a quelle peculiarità del Made in Italy (materiali pregiati, qualità dei progetti e dei prodotti) che sono parte integrante della filosofia aziendale. In questo contesto, negli ultimi anni è accresciuta la presenza del marchio all'interno dei punti vendita in tutto il mondo, non solo con singoli prodotti, ma con spazi dedicati.

En

Awards

The awards bestowed upon Bonaldo over the years have definitely enhanced brand and product awareness, in Italy and especially abroad, where particular focus is placed on excellence Made in Italy (fine materials, quality designs and products) which form an integral part of the corporate philosophy. To this end, the brand's presence has grown in outlets across the globe, and not just with individual products, but with dedicated spaces too.

De

Preise

Die Preise, die Bonaldo in diesen Jahren erhalten hat, haben sicher die Bekanntheit der Marke und der Produkte in Italien und vor allem im Ausland, wo die Qualitäten des Labels „Made in Italy“ (hochwertige Materialien, hohe Qualität der Entwürfe und Produkte) - ein fester Bestandteil der Firmenphilosophie - große Beachtung finden, gefördert. Dadurch ist in den vergangenen Jahren die Präsenz der Marke in den Verkaufsstellen weltweit gestiegen, und nicht nur mit Einzelprodukten sondern auch mit Verkaufsflächen, die der Marke gewidmet sind.

Fr

Prix

Les prix obtenus au fil des ans par Bonaldo ont sans aucun doute renforcé la notoriété de la marque et de ses produits, non seulement en Italie, mais aussi à l'étranger, où l'on accorde une attention particulière au Made in Italy et à ses spécificités (matériaux nobles, projets et produits de qualité), qui font partie intégrante de la philosophie d'entreprise. Dans ce contexte, la présence de la marque s'est intensifiée au cours de ces dernières années dans les points de vente du monde entier, et non seulement en termes de produits proposés mais également en surface d'espaces dédiés.

BEST
DESIGN

reddot design award



Tavoli. Tables. Tische. Tables.

Amond
P.80



AX
P.20



Big Table
P.42



Chat / Chat Double
P.244



Flag
P.166

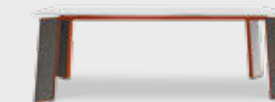

Fli
P.252

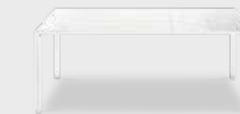

Gap
P.174



Greeny
P.138



Hulahoop
P.90

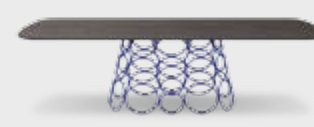

Kime
P.238



Mass Table
P.34



Match
P.188



Medley
P.148



Menu
P.228



Mille
P.206



Octa
P.110



Prora
P.98



Sol
P.220



Still
P.194



TL
P.68



Tom
P.212



Tracks
P.126



Twice
P.158



Vanessa
P.200



Welded
P.182



Bonaldo presenta la nuova Collezione Tavoli: una continua ricerca di oggetti dalla personalità spiccata, una proposta che ogni anno si allarga per ampliare la possibilità di scelta di un pubblico che richiede qualità e originalità.
Una Collezione di oggetti realizzati in collaborazione con grandi designer internazionali. Legni, metalli, cristalli, marmi: materiali selezionati e di pregio assoluto, materiali che danno al prodotto il valore di un'immediata riconoscibilità e di forte identità formale.
La Collezione Tavoli Bonaldo: un mondo di qualità e valore.



Tavoli. Tables. Tische. Tables.

En Bonaldo is pleased to present the new Table Collection - an ongoing quest for items with a distinctive personality, a collection which grows every year in order to offer more choice to customers looking for quality and originality. A collection of items made in association with great international designers. Wood, metal, glass and marble: selected and absolutely prestigious materials that give products the value of immediate recognition and a strong formal identity. The Bonaldo Table Collection: a world of quality and value.

De Bonaldo präsentiert die neue Tischkollektion. Ergebnis unserer beständigen Suche nach Stücken mit unverfälscht ausdrucksstarkem Design. Ein Angebot, das von Jahr zu Jahr wächst – und damit auch die Auswahl für alle, die Qualität und Originalität suchen. Eine Produktkollektion, die in Zusammenarbeit mit zahlreichen internationalen Designgrößen entstand. Holz, Metall, Glas, Marmor: ausgewählte, hochwertige Materialien, die den Produkten einen hohen Wiedererkennungswert und ihren Formen individuellen Charakter verleihen. Die Tischkollektion von Bonaldo: Qualität und Wertigkeit garantiert.

Fr Bonaldo présente sa nouvelle Collection Tables : une recherche continue d'objets à la personnalité forte, une proposition qui chaque année s'enrichit pour élargir les possibilités de choix, pour un public toujours en quête de produits originaux et de qualité. Une Collection d'objets réalisés en collaboration avec de grands designers internationaux. Bois, métaux, cristaux, marbres, des matériaux nobles, soigneusement sélectionnés pour des produits porteurs d'une forte identité formelle et aisément reconnaissable. La Collection de tables Bonaldo est l'expression d'un univers de qualité et de valeur.



AX

Il tavolo AX: un nome che esprime perfettamente le caratteristiche formali della base, realizzata mediante due elementi che si incrociano a X. Essenzialità geometrica e linearità sono scelte di un linguaggio progettuale improntato alla semplicità, ma connotato anche da una solida concretezza.

En The AX Table: a name that perfectly express the formal features of the base, which is made of two elements crossing over in an X shape. Geometric elementary appeal and linearity are choices of a design language based on simplicity but also connoted by solid concreteness.

Fr La table AX, un nom qui exprime parfaitement les caractéristiques formelles de la base, réalisée à partir de deux éléments qui se croisent pour former un X. Géométrie linéaire et sobriété sont les clés d'un langage conceptuel empreint de simplicité et de pragmatisme.

De AX: Der Name verweist bereits auf die charakteristische Form des Gestells, das aus zwei förmig gekreuzten Elementen besteht. Geometrisch und linear gehalten präsentiert sich sein Design aufs Wesentliche reduziert, vermittelt aber zugleich Konkretheit und Beständigkeit.

AX Gino Carollo
Tavolo. Table. Tisch. Table.

Noce americano / grigio antracite
American walnut / anthracite grey
Amerikaner Nussbaum / Anthrazitgrau
Noyer américain / anthracite grey



AX Gino Carollo
Tavolo. Table. Tisch. Table.

Flute Mauro Lipparini
Sedia. Chair. Stuhl. Chaise.

Pag. 22-23, 24, 25
Ceramica Calacatta / grigio antracite
Calacatta ceramic / anthracite grey
Calacatta Ceramic / Anthrazitgrau
Céramique Calacatta / gris anthracite

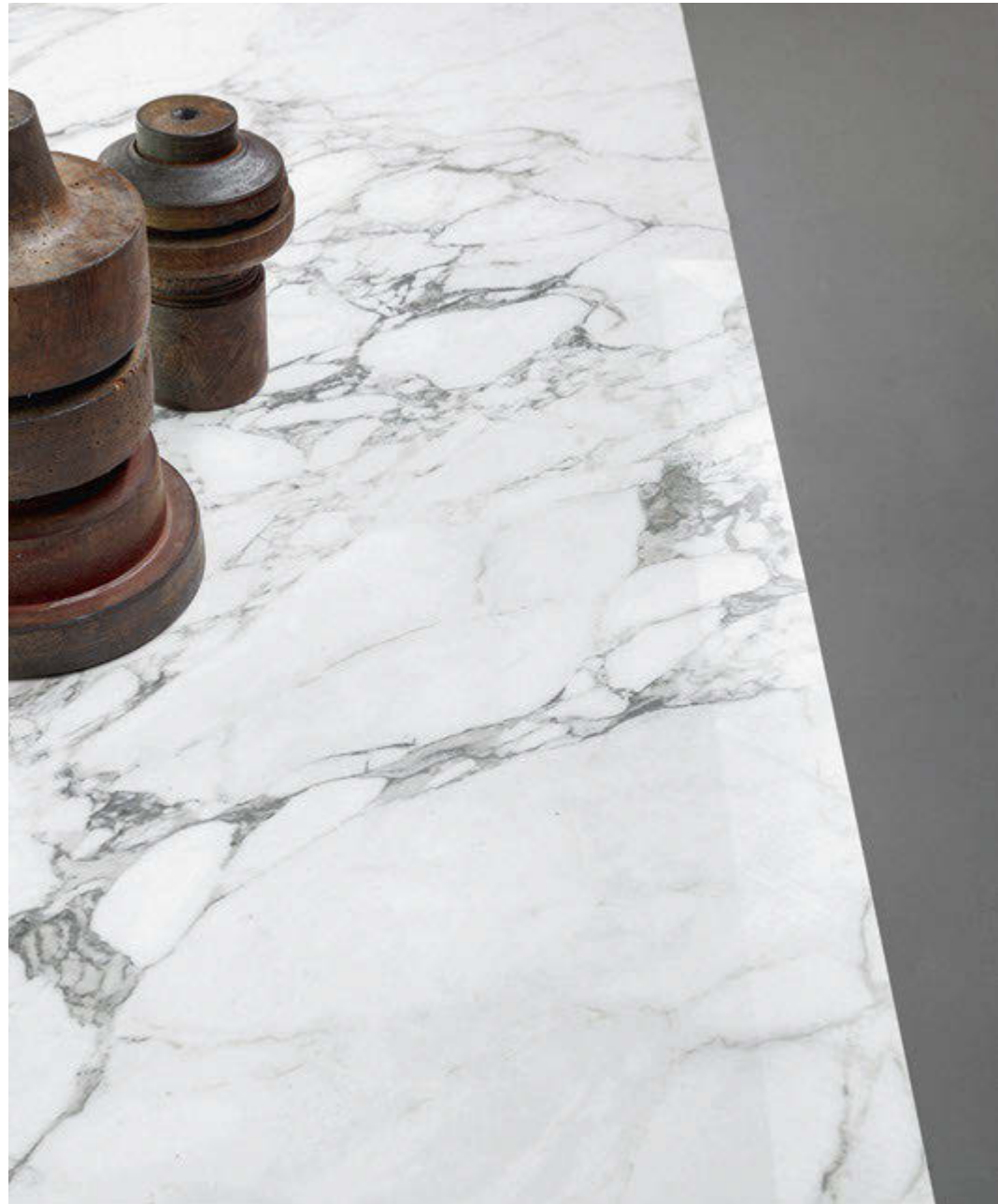

AX Gino Carollo
Tavolo. Table. Tisch. Table.

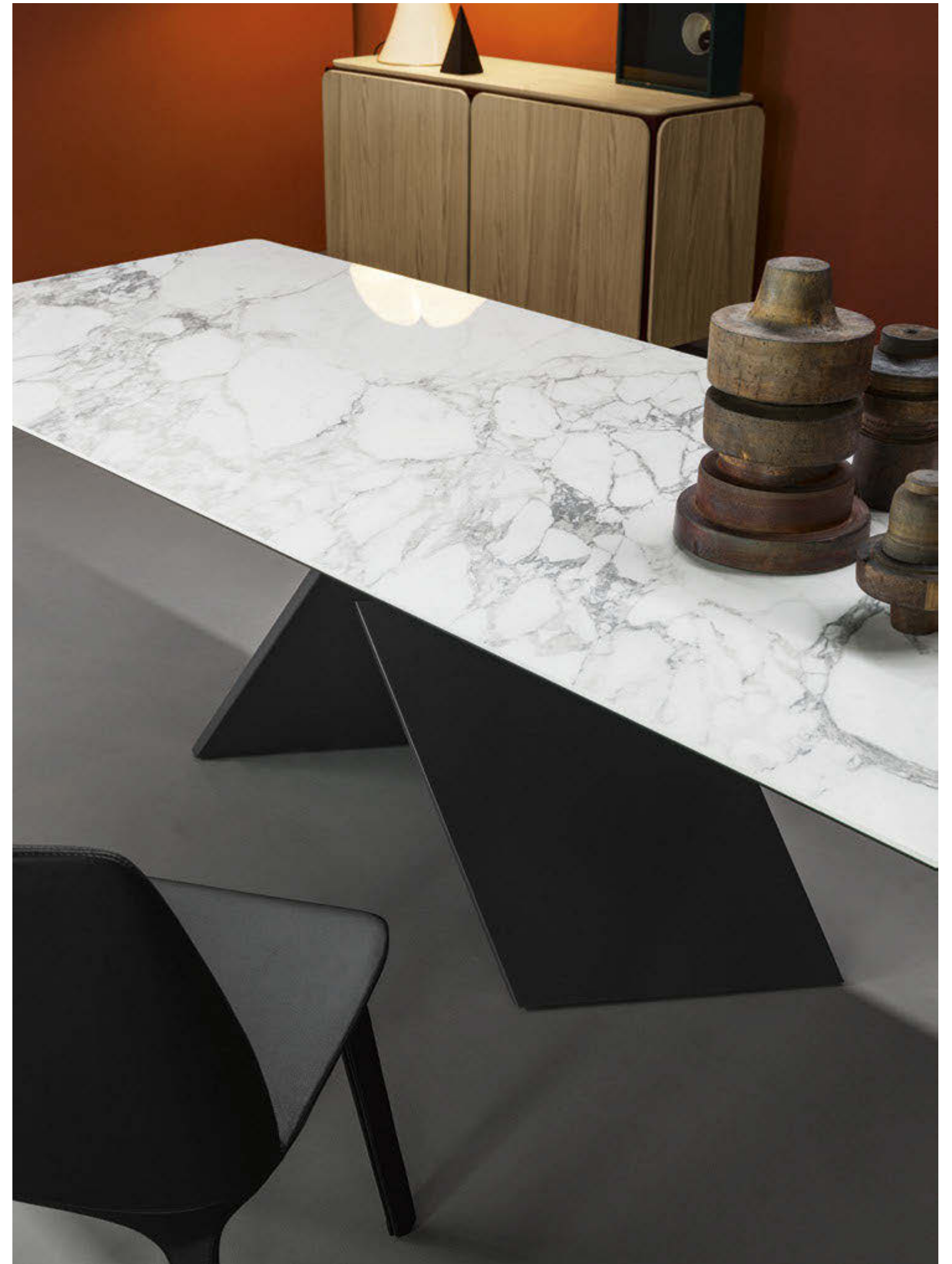



AX Gino Carollo
 Tavolo. Table. Tisch. Table. **Pag. 26-27, 28-29**
 Noce americano con bordi naturali / brunito
Filly up Bartoli Design
 American walnut with natural edges / burnished
 Sedia. Chair. Stuhl. Chaise. Amerikaner Nussbaum mit Waldkante / Brüniert
 Noyer américain avec contour naturel / bruni



AX Gino Carollo
Tavolo. Table. Tisch. Table.

Filly up Bartoli Design
Sedia. Chair. Stuhl. Chaise.





AX Gino Carollo
 Tavolo. Table. Tisch. Table.
Flute Mauro Lipparini
 Sedia. Chair. Stuhl. Chaise.

Pag. 30-31, 32, 33
 Ceramica Paonazetto / grigio antracite
 Paonazetto ceramic / anthracite grey
 Paonazetto Ceramic / Anthrazitgrau
 Céramique Paonazetto / gris anthracite



AX Gino Carollo
Tavolo. Table. Tisch. Table.

Flute Mauro Lipparini
Sedia. Chair. Stuhl. Chaise.



Mass Table

Ribaltare il rapporto tradizionale tra base e piano: Mass Table, disegnato da Alain Gilles per festeggiare l'ottantesimo compleanno di Bonaldo, ha la base connotata da una leggerezza formale che ricorda un po' le crinoline vittoriane e un po' un wireframe tridimensionale. Il piano occupa lo spazio visivo con una forte personalità estetica.

En It overturns the traditional relationship between the base and the top. Mass Table, designed by Alain Gilles to celebrate Bonaldo's eightieth birthday, has a base connoted by a formal lightness that resembles Victorian crinolines as well as a 3D wire frame. The top occupies the visual space with a strong aesthetic personality.

De Hier wird das traditionelle Verhältnis zwischen Gestell und Tischplatte einfach umgedreht. Der von Alain Gilles zum 80-jährigen Jubiläum von Bonaldo entworfene Mass Table überrascht mit einem Gestell von unerwarteter Leichtigkeit. Seine Form erinnert ein wenig an das Gerüst viktorianischer Reifröcke, aber auch an dreidimensionale Drahtgittermodelle. Optisch dominiert jedoch die ausdrucksstarke Ästhetik der Tischplatte.

Fr Mass Table ou comment renverser le rapport traditionnel entre base et plateau. Dessinée par Alain Gilles à l'occasion du 80ème anniversaire de Bonaldo, Mass Table présente une base légère qui n'est pas sans rappeler les crinolines victoriennes, mais aussi les wireframe 3D. Quant au plateau, il occupe l'espace visuel avec une forte personnalité esthétique.

Pag 35, 36, 37

Rovere grigio antracite / finitura rame opaco
Anthracite grey oak / mat copper finish
Eiche Anthrazitgrau / Kupfer matt Ausführung
Rouvre gris anthracite / finition cuivre opaque

Mass Table Alain Gilles
Tavolo, Table, Tisch, Table.





Mass Table Alain Gilles
Tavolo. Table. Tisch. Table

Tip Toe Mauro Lipparini
Sedia. Chair. Stuhl. Chaise.





Mass Table Alain Gilles
Tavolo. Table. Tisch. Table
Tip Toe Mauro Lipparini
Sedia. Chair. Stuhl. Chaise.

Ceramica Calacatta / finitura rame opaco
Calacatta ceramic / mat copper finish
Calacatta Ceramic / Kupfer matt Ausführung
C ramique Calacatta / finition cuivre opaque





Mass Table Alain Gilles
Tavolo. Table. Tisch. Table

Sheryl Giuseppe Viganò
Sedia. Chair. Stuhl. Chaise.

Cristallo acidato nero / nero
Black acid-treated glass / black
Geätztes Glas Schwarz / Schwarz
Cristal traité à l'acide noir / noir

Big Table

Un gioco di equilibri tra gli elementi, dove lo sguardo si muove seguendo l'alternanza di colori e forme e la spiccata originalità di linee e cromatismi. L'inclinazione delle gambe suggerisce dinamismo, la linearità del piano dona una grande stabilità visiva. Immobile o in movimento, Big Table ha una personalità decisamente fuori dal comune.

En A game of balances between elements, where the gaze moves following the alternation of colours and shapes and the marked originality of lines and colour shades. The inclination of the legs suggests dynamism and the linearity of the top provides great visual stability. Stationary or moving, Big Table really does have an unusual personality.

De Verspielt harmonische Kontraste. Der Blick folgt den verschiedenen Farben und Formen, der außergewöhnlichen Linienführung und Farbgebung. Die schrägen Beine verleihen dem Tisch Big Table lebendige Dynamik, während die geradlinige Tischfläche visuelle Stabilität herstellt. Das Ergebnis ist eine zweifellos außergewöhnliche Optik – bewegt und statisch zugleich.

Fr Un jeu d'équilibres entre les éléments, où le regard suit l'alternance des couleurs et des formes toujours originales. L'inclinaison des pieds suggère le dynamisme, tandis que la linéarité du plateau confère une grande stabilité visuelle. Entre immobilité et mobilité, Big Table possède une personnalité absolument hors du commun.

Big Table Alain Gilles
Tavolo. Table. Tisch. Table.

Pag. 43, 44-45
Noce 400 / finitura bronzo-rame
Walnut 400 / copper-bronze finish
Nussbaum 400 / Kupferbronze Ausführung
Noyer 400 / finition bronze-cuivre

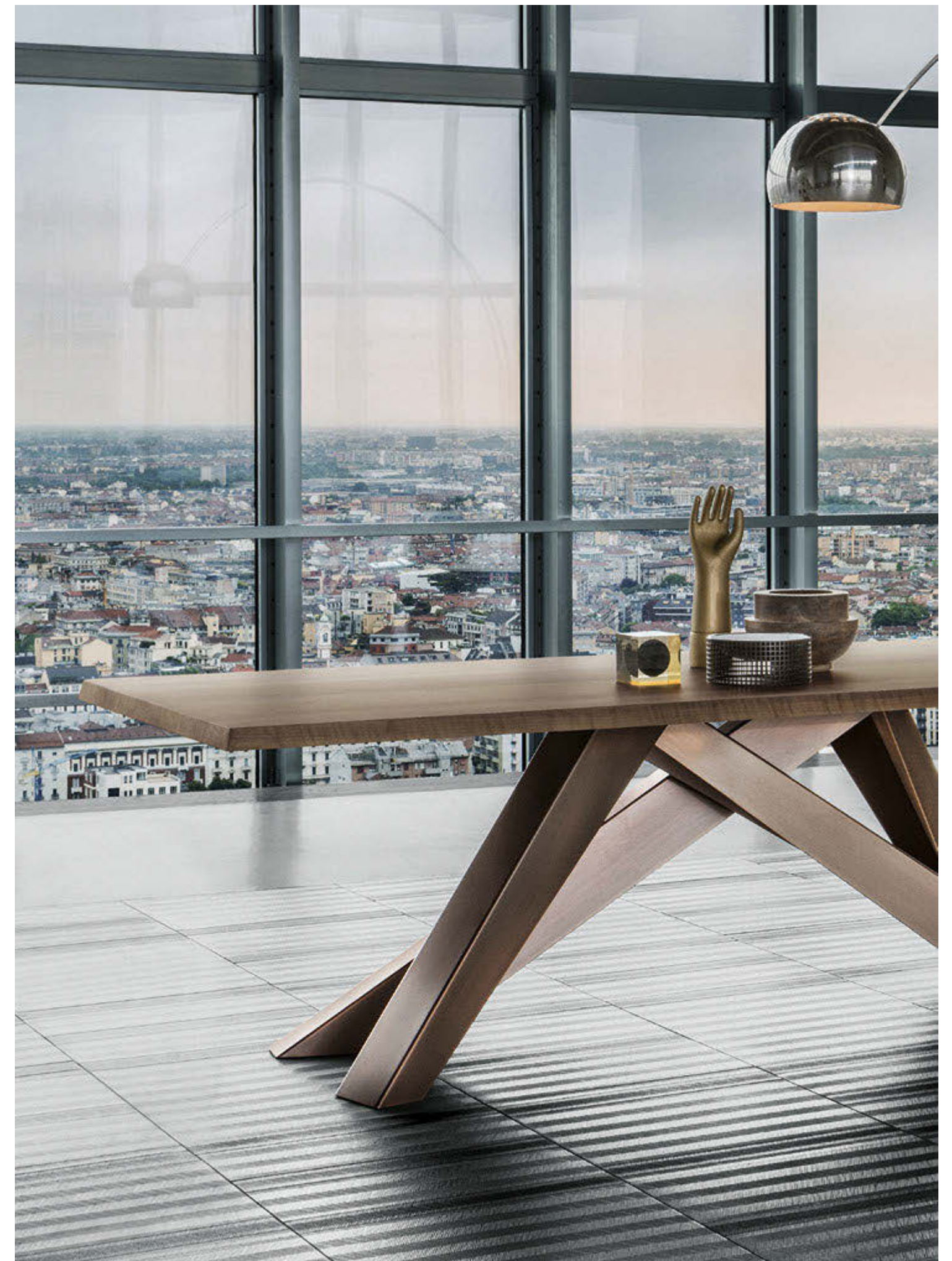



Big Table Alain Gilles
Tavolo. Table. Tisch. Table.

Ketch Bartoli Design
Sedia. Chair. Stuhl. Chaise.



Big Table Alain Gilles
 Tavolo. Table. Tisch. Table
Ketch Bartoli Design
 Sedia. Chair. Stuhl. Chaise.

Noce americano con bordi naturali / finitura bronzo-rame
 American walnut with natural edges / copper-bronze finish
 Amerikaner Nussbaum mit Waldkante / Kupferbronze Ausführung
 Noyer américain avec contour naturel / finition bronze-cuivre





Big Table Alain Gilles
Tavolo. Table. Tisch. Table.

Filly Bartoli Design
Sedia. Chair. Stuhl. Chaise.

Rovere naturale / corten
Natural oak / corten
Eiche Natur / Corten
Rouvre naturel / corten



Big Table Alain Gilles
Tavolo. Table. Tisch. Table
Rovere grigio antracite / corten
Anthracite grey oak / corten
Eiche Anthrazitgrau / Corten
Rouvre gris anthracite / corten





Big Table Alain Gilles
Tavolo. Table. Tisch. Table

Noce americano / rosso corallo-arancio-verde-lilla
American walnut / coral red-orange-green-lilac
Amerikaner Nussbaum / Korallenrot-Orange-Grün-Lila
Noyer américain / rouge corail-orange-vert-lilac



Big Table Alain Gilles
Tavolo. Table. Tisch. Table
Rovere grigio antracite / grigio antracite
Anthracite grey oak / anthracite grey
Eiche Anthrazitgrau / Anthrazitgrau
Rouvre gris anthracite / gris anthracite





Big Table Alain Gilles
Tavolo. Table. Tisch. Table.
Venere Bartoli Design
Sedia. Chair. Stuhl. Chaise.

Noce Canaletto / rosa polvere-marrone-tortora-amaranto
Walnut Canaletto / powder pink-brown-dove grey-amaranth
Nussbaum Canaletto / Puderrosa-Braun-Taubengrau-Amarant
Noyer Canaletto / rose poudré-marron-gris tourterelle-amarante



Big Table Alain Gilles
 Tavolo. Table. Tisch. Table.
Venere Bartoli Design
 Sedia. Chair. Stuhl. Chaise.

Laccato bianco opaco / rosso corallo-arancio-verde-lilla
 Mat white lacquered / coral red-orange-green-lilac
 Weiss matt lackiert / Korallenrot-Orange-Grün-Lila
 Laqué blanc opaque / rouge corail-orange-vert-lilac



Big Table Alain Gilles
Tavolo. Table. Tisch. Table.
Cristallo acidato bianco / bianco
White acid-treated glass / white
Geätztes Glas Weiss / Weiss
Cristal traité à l'acide blanc / blanc



Big Table Alain Gilles
Tavolo. Table. Tisch. Table.
Alanda Gino Carollo
Sedia. Chair. Stuhl. Chaise.

Cristallo acidato bianco / bianco
White acid-treated glass/ white
Geätztes Glas Weiss / Weiss
Cristal traité à l'acide blanc / blanc





Big Table Alain Gilles
Tavolo. Table. Tisch. Table.
Filly up Bartoli Design
Sedia. Chair. Stuhl. Chaise.

Rovere termotrattato / grigio antracite
Heat-treated oak / anthracite grey
Thermo-behandelte Eiche / Anthrazitgrau
Rouvre traité thermiquement / gris anthracite



Big Table Alain Gilles
 Tavolo. Table. Tisch. Table.
Venere Bartoli Design
 Sedia. Chair. Stuhl. Chaise.

Noce Canaletto / rosso corallo-arancio-verde-lilla
 Walnut Canaletto / coral red-orange-green-lilac
 Nussbaum Canaletto / Korallenrot-Orange-Grün-Lila
 Noyer Canaletto / rouge corail-orange-vert-lilac



TL

Due elementi inclinati e di forte spessore, immagine di solidità e di stabilità: il nome del tavolo TL è dovuto alla particolare sagoma del basamento centrale che, insieme al piano, forma le due lettere T ed L. Le linee sono nette e sono in grado di disegnare lo spazio domestico con grande originalità.

En Two inclined and very thick elements, an image of solidity and stability. The TL table is named after the unusual shape of the central base which, along with the top, forms the two letters T and L. The lines are clean cut and define the domestic space with great originality.

De Zwei massive, schräg angeordnete Elemente, die das Gefühl von Beständigkeit und Stabilität vermitteln. Der Tisch TL verdankt seinen Namen der außergewöhnlichen Form des zentralen Tischbeins, das zusammen mit der Tischplatte die Buchstaben T und L formt. Mit seiner klaren Linienführung setzt er im Raum starke Akzente.

Fr Deux éléments inclinés et de forte épaisseur, représentant l'image même de la solidité et la stabilité. Le nom de la table TL dérive de la forme particulière de la base centrale qui, avec le plateau, forme les deux lettres T et L. Nettes, les lignes dessinent l'espace domestique de manière extrêmement originale.

TL Giuseppe Viganò
Tavolo. Table. Tisch. Table.

Kayla up Dondoli e Pocci
Sedia. Chair. Stuhl. Chaise.

Noce americano / decapato
American walnut / pickled
Amerikaner Nussbaum / Stahlgrau
Noyer américain / décapé





TL Giuseppe Viganò
 Tavolo. Table. Tisch. Table.
Filly up Bartoli Design
 Sedia. Chair. Stuhl. Chaise.

Rovere naturale / decapato
 Natural oak / pickled
 Eiche Natur / Stahlgrau
 Rouvre naturel / décapé



TL Giuseppe Viganò
 Tavolo. Table. Tisch. Table.
Filly up Bartoli Design
 Sedia. Chair. Stuhl. Chaise.

Rovere termotrattato / grigio antracite
 Heat-treated oak / anthracite grey
 Thermo-behandelte Eiche / Anthrazitgrau
 Rouvre traité thermiquement / gris anthracite



TL Giuseppe Viganò
 Tavolo. Table. Tisch. Table.
Filly Bartoli Design
 Sedia. Chair. Stuhl. Chaise.

Rovere naturale / bianco
 Natural oak / white
 Eiche Natur / Weiss
 Rouvre naturel / blanc



TL Giuseppe Viganò
Tavolo. Table. Tisch. Table.
Kayla up Dondoli e Pocci
Sedia. Chair. Stuhl. Chaise.

Noce americano / finitura rame / decapato
American walnut / copper finish / pickled
Amerikaner Nussbaum / Kupfer Ausführung / Stahlgrau
Noyer américain / finition cuivre / décapé





TL Giuseppe Viganò
Tavolo. Table. Tisch. Table.
Napi Bartoli Design
Sedia. Chair. Stuhl. Chaise.

Laccato bianco opaco / bianco
Mat white lacquered / white
Weiss matt lackiert / Weiss
Laqué blanc opaque / blanc



Amond

Un piano di spessore importante, con gli angoli ben delineati; una base dal disegno geometrico, caratterizzata dall'assenza di volumi pieni. Il tavolo Amond mantiene un grande senso di equilibrio proprio grazie alla contrapposizione tra piano e base, creando quasi l'illusione di un piano sospeso.

En A very thick top, with clearly defined corners; a base with a geometric design, which stands out due to the absence of full volumes. The Amond table maintains a great sense of balance through the contrast between the top and the base, almost creating the illusion of a suspended top.

De Eine massive Tischplatte mit klar definierten Kanten kombiniert mit einem geometrisch geformten Gestell mit minimalem materiellem Volumen. Der Tisch Amond präsentiert ein ausgewogenes Gesamtbild, das auf dem bewussten Kontrast zwischen Tischplatte und Gestell beruht und die Tischplatte optisch beinahe schweben lässt.

Fr Un plateau d'une épaisseur importante, aux angles bien définis, et une base au design géométrique, caractérisée par l'absence de volumes pleins. La table Amond maintient un grand sens de l'équilibre grâce justement à l'opposition entre le plan et la base, créant ainsi l'illusion d'un plateau suspendu.

Amond Gino Carollo
Tavolo. Table. Tisch. Table.

Ceramica Calacatta / decapato
Calacatta ceramic / pickled
Calacatta Ceramic / Stahlgrau
Céramique Calacatta / décapé

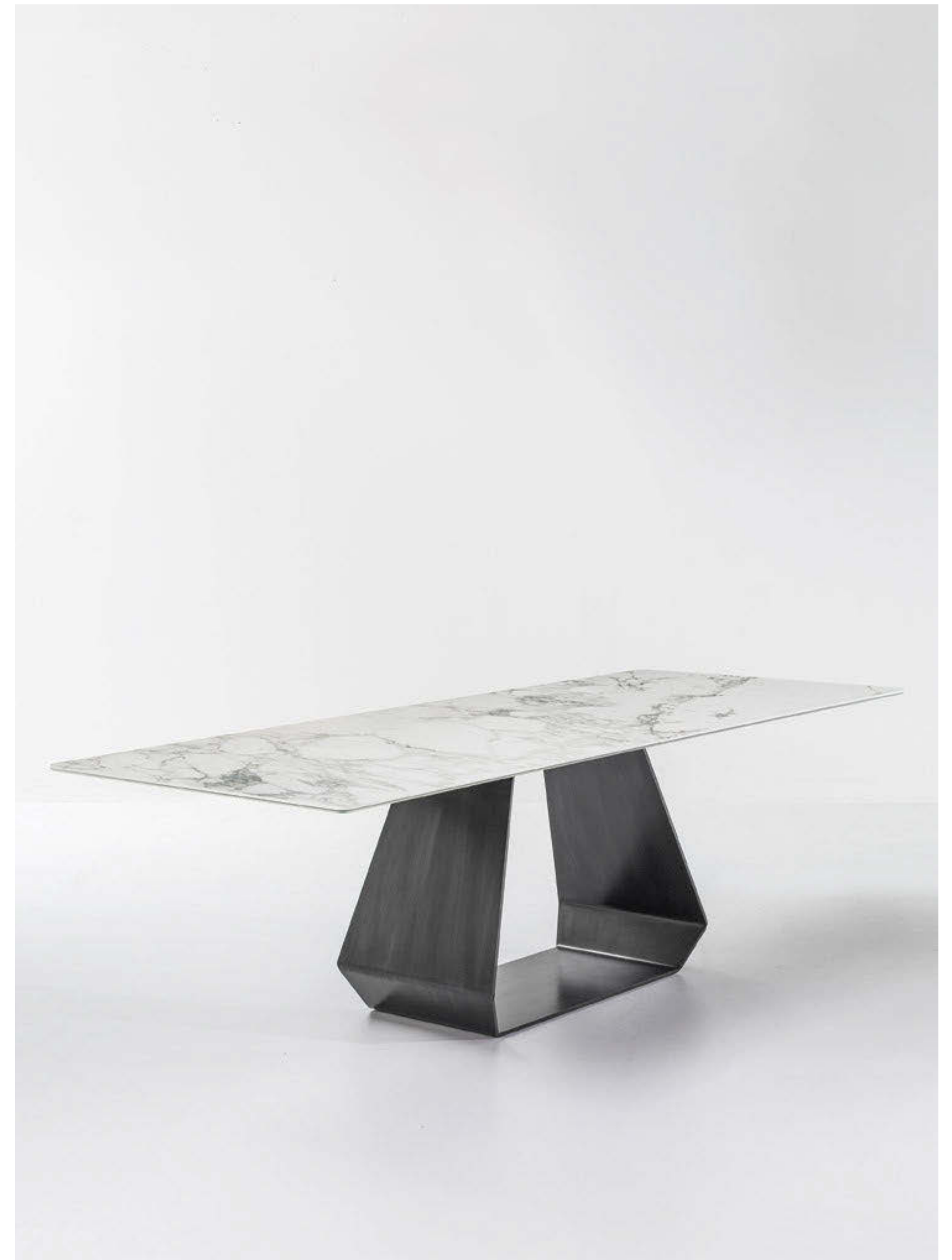



Amond Gino Carollo
Tavolo. Table. Tisch. Table.
Lamina Mauro Lipparini
Sedia. Chair. Stuhl. Chaise.

Rovere grigio antracite / decapato
Anthracite grey oak / pickled
Eiche Anthrazitgrau / Stahlgrau
Rouvre gris anthracite / décapé





Amond Gino Carollo
Tavolo. Table. Tisch. Table.

Lamina Mauro Lipparini
Sedia. Chair. Stuhl. Chaise.

Pag. 84-85, 86, 87

Noce Canaletto / decapato
Walnut Canaletto / pickled
Nussbaum Canaletto / Stahlgrau
Noyer Canaletto / décapé



Amond Gino Carollo
Tavolo. Table. Tisch. Table.





Amond Gino Carollo
Tavolo. Table. Tisch. Table.
Natural oak / polished steel

Lamina Mauro Lipparini
Sedia. Chair. Stuhl. Chaise.
Eiche Natur / Stahl poliert
Rouvre naturel / acier brossé

Hulahoop

Una famiglia di tavoli che deve il suo nome all'hulahoop, il divertente gioco connotato dall'idea del movimento. Un tavolo che ha un piano minimale e il cerchio come figura di riferimento della base: anelli affiancati che si sviluppano nello spazio, creando un oggetto dall'immagine giocosa e dinamica, sempre diversa a seconda del punto di vista.

En A family of tables that owes its name to the hula hoop, the fun toy connoted by the idea of movement. A table that has a minimal top and the circle as a reference figure for the base, overlapping rings that extend into space, creating an item with a playful and dynamic image, always different according to the point of view.

De Benannt ist die Tischserie Hulahoop nach dem bekannten lustigen Spielzeug, bei dem sich alles um Bewegung dreht. Die Tischplatte selbst ist minimalistisch gehalten, die Figur des Reifens prägt das Design des Gestells. Mehrere Reihen von Ringen heben sich von der Umgebung ab und lassen ein verspieltes, dynamisches Bild entstehen, das sich je nach Blickwinkel ändert.

Fr Une famille de tables qui doit son nom au hulahoop, le cerceau amusant qui donne immédiatement l'idée de mouvement. Une table avec un plateau minimal et le cercle comme figure de référence de la base : les uns à côté des autres, les anneaux se multiplient dans l'espace pour créer un objet à la connotation ludique et dynamique, toujours différent selon la perspective à partir de laquelle on se place.

Pag. 91. 93

Marmo Calacatta lucido / grigio antracite
Glossy Calacatta marble / anthracite grey
Glänzend Calacatta Marmor / Anthrazitgrau
Marbre Carrara brillant / gris anthracite

Hulahoop Alessandro Busana
Tavolo. Table. Tisch. Table.

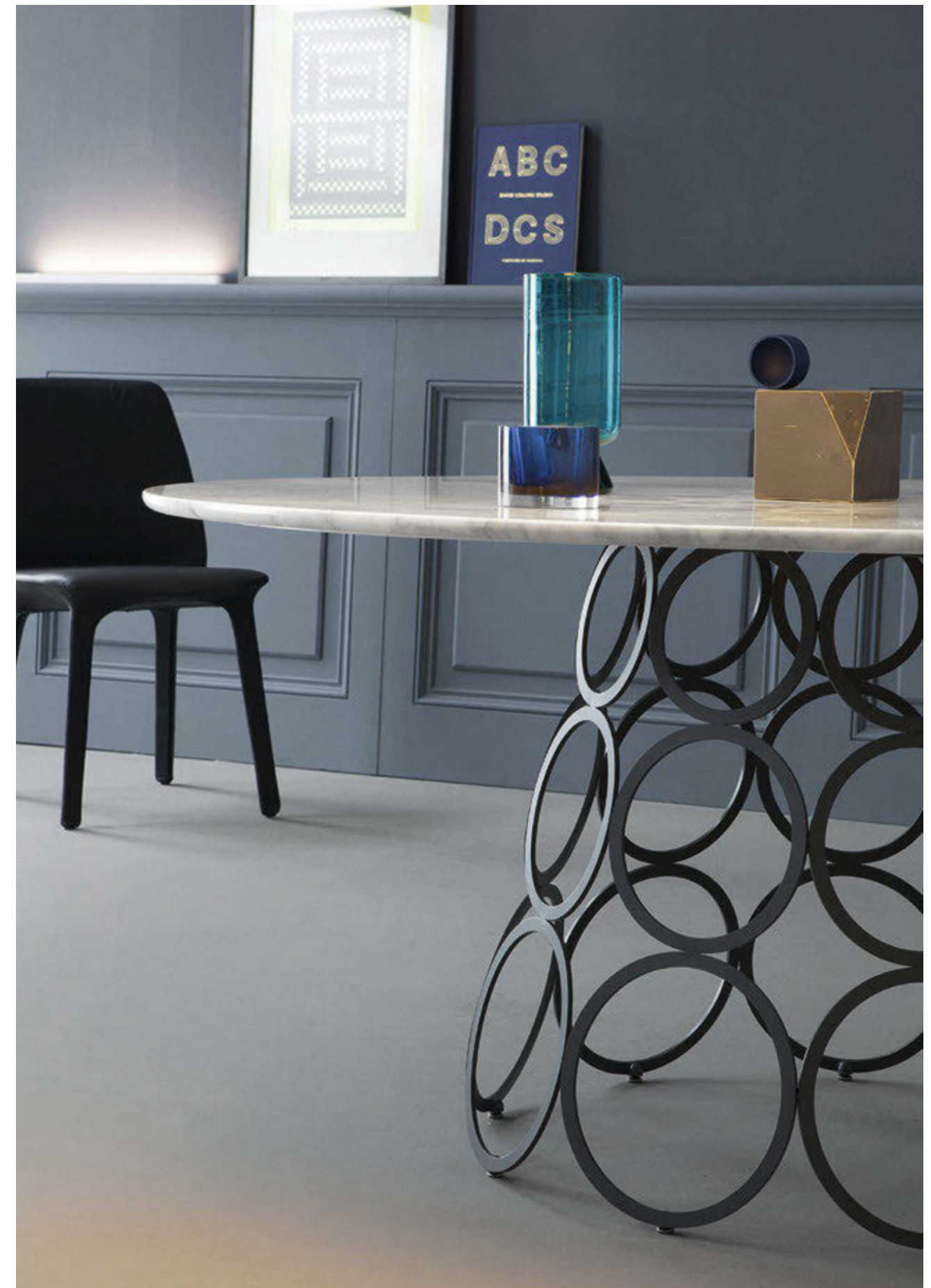



Hulahoop Alessandro Busana
Tavolo. Table. Tisch. Table.

Flute Mauro Lipparini
Sedia. Chair. Stuhl. Chaise.

Cristallo acidato nero / grigio antracite
Black acid-treated glass / anthracite grey
Geätztes Glas Schwarz / Anthrazitgrau
Cristal traité à l'acide noir / gris anthracite



Hulahoop Alessandro Busana
Tavolo. Table. Tisch. Table.

Flute Mauro Lipparini
Sedia. Chair. Stuhl. Chaise.



Hulahoop Alessandro Busana
Tavolo. Table. Tisch. Table.

Ketch Bartoli Design
Sedia. Chair. Stuhl. Chaise.

Noce americano / decapato
American walnut / pickled
Amerikaner Nussbaum / Stahlgrau
Noyer américain / décapé



Hulahoop Alessandro Busana
Tavolo. Table. Tisch. Table.

Rovere grigio antracite / blu
Anthracite grey oak / blue
Eiche Anthrazitgrau / Blau
Rouvre gris anthracite / bleu

Prora

Le gambe ricordano una scultura moderna con la forma della prua di una nave. Prora è un tavolo di assoluta riconoscibilità estetica. Garantisce alti livelli di funzionalità, grazie alle prolunghe laterali indipendenti, che permettono di aumentare con facilità la lunghezza del piano, mantenendo un'ottima stabilità e solidità. Il piano è disponibile anche nella versione fissa.

En Its legs resemble a modern sculpture with the shape of the prow of a ship. Prora is a table with absolute aesthetic recognition. It guarantees high levels of functionality, due to the independent side extensions, which make it possible to increase the length of the table top easily, while retaining ultimate stability and solidity. The top is also available in the fixed version.

De Seine Beine erinnern an eine moderne Skulptur, an die Form eines Schiffbugs. Die Ästhetik des Tisches Prora überzeugt durch ihren hohen Wiedererkennungswert. Dank der separaten seitlichen Verlängerungen bietet Prora zudem ein Maximum an Funktionalität. Die Auflagefläche kann jederzeit problemlos vergrößert werden, ohne dadurch die Stabilität und Standfestigkeit des Tisches zu beeinträchtigen. Erhältlich auch mit nicht ausziehbarer Tischplatte.

Fr Les pieds évoquent une sculpture moderne à la forme d'une proue de bateau. Prora est une table à l'esthétique aisément reconnaissable. Son côté extrêmement fonctionnel est assuré par les deux rallonges latérales et indépendantes qui permettent d'augmenter facilement la longueur du plateau tout en maintenant une excellente stabilité et solidité. Le plateau est également disponible en version fixe.

Prora Mauro Lipparini
Tavolo. Table. Tisch. Table.

Filly up Bartoli Design
Sedia. Chair. Stuhl. Chaise.

Rovere termotrattato / decapato
Heat-treated oak / pickled
Thermo-behandelte Eiche / Stahlgrau
Rouvre traité thermiquement / décapé





Prora Mauro Lipparini
Tavolo. Table. Tisch. Table.
Natural oak with knots / polished steel

Venere Bartoli Design
Sedia. Chair. Stuhl. Chaise.
Eiche Natur mit Knoten/ Stahl poliert
Rouvre naturel avec noeuds / acier brossé



Prora Mauro Lipparini
Tavolo. Table. Tisch. Table.
Noce 400 / acciaio spazzolato
Walnut 400 / polished steel

Alanda Gino Carollo
Sedia. Chair. Stuhl. Chaise.
Nussbaum 400 / Stahl poliert
Noyer 400 / acier brossé



Prora Mauro Lipparini
Tavolo. Table. Tisch. Table.

My Time Dondoli e Poggi
Sedia. Chair. Stuhl. Chaise.

Cristallo acidato nero / grigio antracite
Black acid-treated glass / anthracite grey
Geätztes Glas Schwarz / Anthrazitgrau
Cristal traité à l'acide noir / gris anthracite



Prora Mauro Lipparini
Tavolo. Table. Tisch. Table.

Cristallo acidato nero / decapato
Black acid-treated glass / pickled
Geätztes Glas Schwarz / Stahlgrau
Cristal traité à l'acide noir / décapé



Prora Mauro Lipparini
Tavolo. Table. Tisch. Table.

Alanda Gino Carollo
Sedia. Chair. Stuhl. Chaise.

Cristallo acidato bianco / bianco
White acid-treated glass / white
Geätztes Glas Weiss / Weiss
Cristal traité à l'acide blanc / blanc



Octa

Octa deriva dal greco “okto” che significa otto: il numero delle gambe del tavolo Octa, che presenta una fitta rete di elementi in metallo che ne caratterizzano la base. Un’idea nata giocando con i bastoncini dello Shangai: disordine ordinato e leggerezza, per un tavolo decisamente inconsueto ed elegante. Il piano è disponibile rettangolare nelle versioni fisso o allungabile, oppure rotondo nella versione fissa.

En Octa comes from the Greek “okto” meaning eight, the number of legs that the Octa table has, with a thick web of metal elements featured in the base. An idea that comes from the “pick-up sticks” game: ordered disorder and lightness, for a decisively unusual and elegant table. The top can be fixed or extendible in the rectangular version, or fixed if round.

De Octa leitet sich vom griechischen Wort “okto” ab, das acht bedeutet. Entsprechend der Anzahl der Beine von Octa, dessen Gestell aus einem dichten Geflecht an Metallstäben besteht. Die Idee für den Tisch entstand beim Spiel mit Mikado-Stäbchen – geordnete Unordnung und Leichtigkeit als Merkmale eines ebenso ungewöhnlichen wie eleganten Tisches. Erhältlich mit rechteckiger, ausziehbarer oder nicht ausziehbarer Tischplatte oder in runder, nicht ausziehbarer Ausführung.

Fr Octa dérive du mot grec “okto”, soit huit en français, huit comme le nombre des pieds de la table, dont la base est caractérisée par un dense réseau de tiges métalliques. Une idée née du jeu du mikado : désordre ordonné et légèreté pour une table décidément originale et élégante. Le plateau est disponible en version rectangulaire (fixe ou extensible) ou ronde (fixe uniquement).

Octa Bartoli Design
Tavolo. Table. Tisch. Table.

Flute Mauro Lipparini
Sedia. Chair. Stuhl. Chaise.

Pag. 111, 112-113

Cristallo acidato nero / black nickel
Black acid-treated glass / black nickel
Geätztes Glas Schwarz / Schwarz vernickelt
Cristal traité à l'acide noir / noir nickel





Octa Bartoli Design
Tavolo. Table. Tisch. Table.



Octa Bartoli Design
Tavolo. Table. Tisch. Table.
Rovere grigio antracite / grigio antracite
Anthracite grey oak / anthracite grey

Filly up Bartoli Design
Sedia. Chair. Stuhl. Chaise.
Eiche Anthrazitgrau / Anthrazitgrau
Rouvre gris anthracite / gris anthracite



Octa Bartoli Design
Tavolo. Table. Tisch. Table.
Eral
Sedia. Chair. Stuhl. Chaise.

Noce americano / cromato
American walnut / chromed
Amerikaner Nussbaum / Verchromt
Noyer américain / chromé



Octa Bartoli Design
Tavolo. Table. Tisch. Table.
Filly Bartoli Design
Sedia. Chair. Stuhl. Chaise.

Ceramica bianco iridium / cromato
White iridium ceramic / chromed
Weiss Iridium Keramic / Verchromt
Céramique blanc iridium / chromé





Octa Bartoli Design
Tavolo. Table. Tisch. Table.
Cristallo acidato bianco / bianco
White acid-treated glass / white

Filly Bartoli Design
Sedia. Chair. Stuhl. Chaise.
Geätztes Glas Weiss / Weiss
Cristal traité à l'acide blanc / blanc



Octa Bartoli Design
Tavolo. Table. Tisch. Table.
Filly up Bartoli Design
Sedia. Chair. Stuhl. Chaise.

Cristallo acidato nero / grigio antracite
Black acid-treated glass / anthracite grey
Geätztes Glas Schwarz / Anthrazitgrau
Cristal traité à l'acide noir / gris anthracite



Octa Bartoli Design
Tavolo. Table. Tisch. Table.
Filly Bartoli Design
Sedia. Chair. Stuhl. Chaise.

Cristallo trasparente / cromato
Transparent glass / chromed
Klarglas / Verchromt
Cristal transparent / chromé

Tracks

I binari, "tracks" in inglese, sono i due assi paralleli in acciaio che costituiscono il meccanismo di allungo del piano e che determinano l'estetica del tavolo. Piano in cristallo, binari in acciaio, base in legno: Tracks è un tavolo allungabile che, con la variazione dei dettagli cromatici e dei materiali, riesce a conferire alle diverse versioni personalità completamente differenti.

En The "tracks" are two parallel steel beams which make up the table top extension mechanism and determine the styling of the table. With a glass top, steel tracks and wooden base, Tracks is an extendible table which, by varying the colour details and materials, succeeds in giving completely different personalities to the different versions.

De An „Schienen“ (Englisch: „tracks“) erinnern die zwei parallelen Achsen aus Stahl, die nicht nur zur Verlängerung der Tischplatte dienen, sondern zugleich entscheidend das Design des Tisches prägen. Tischplatte aus Glas, Schienen aus Stahl, Gestell aus Holz: Farbe und Ausführung der einzelnen Materialien entscheiden wesentlich über die optische Wirkung des ausziehbaren Tisches Tracks.

Fr Les deux axes parallèles en acier des rails, « tracks » en anglais, constituent non seulement le mécanisme de rallonge du plateau, mais aussi l'élément fondamental de l'esthétique de la table. Plateau en cristal, rails en acier, base en bois : Tracks est une table extensible dont la personnalité change en fonction des détails chromatiques et des matériaux choisis.

Tracks Alain Gilles
Tavolo. Table. Tisch. Table.

My Time Dondoli e Poggi
Sedia. Chair. Stuhl. Chaise.

Pag|27, 128, 129

Cristallo extrachiaro trasparente / rosso / frassino naturale
Extra-light transparent glass / red / natural ash
Klarglas extra-hell / Rot / Eschenholz Natur
Cristal extra-clair transparent / rouge / frêne naturel





Tracks Alain Gilles
Tavolo. Table. Tisch. Table.

My Time Dondoli e Pocci
Sedia. Chair. Stuhl. Chaise.





Tracks Alain Gilles
 Tavolo. Table. Tisch. Table.
Kuva soft Bartoli Design
 Sedia. Chair. Stuhl. Chaise.

Cristallo extrachiaro trasparente / blu / frassino grigio
 Extra-light transparent glass / blue / grey ash
 Klarglas extra-hell / Blau / Eschenholz Grau
 Cristal extra-clair transparent / bleu / frêne gris



Tracks Alain Gilles
Tavolo. Table. Tisch. Table.

Cristallo extrachiaro trasparente / giallo zafferano / noce americano
Extra-light transparent glass / saffron yellow / American walnut
Klarglas extra-hell / Safrangelb / Amerikaner Nussbaum
Cristal extra-clair transparent / jaune safran / noyer américain



Tracks Alain Gilles
Tavolo. Table. Tisch. Table.

Miss Kuva large soft Bartoli Design
Sedia. Chair. Stuhl. Chaise.

Pag. 134-135, 136, 137

Cristallo extrachiaro trasparente / grigio antracite / frassino grigio
Extra-light transparent glass / anthracite grey / grey ash
Klarglas extra-hell / Anthrazitgrau / Eschenholz Grau
Cristal extra-clair-transparent / gris anthracite / frêne gris

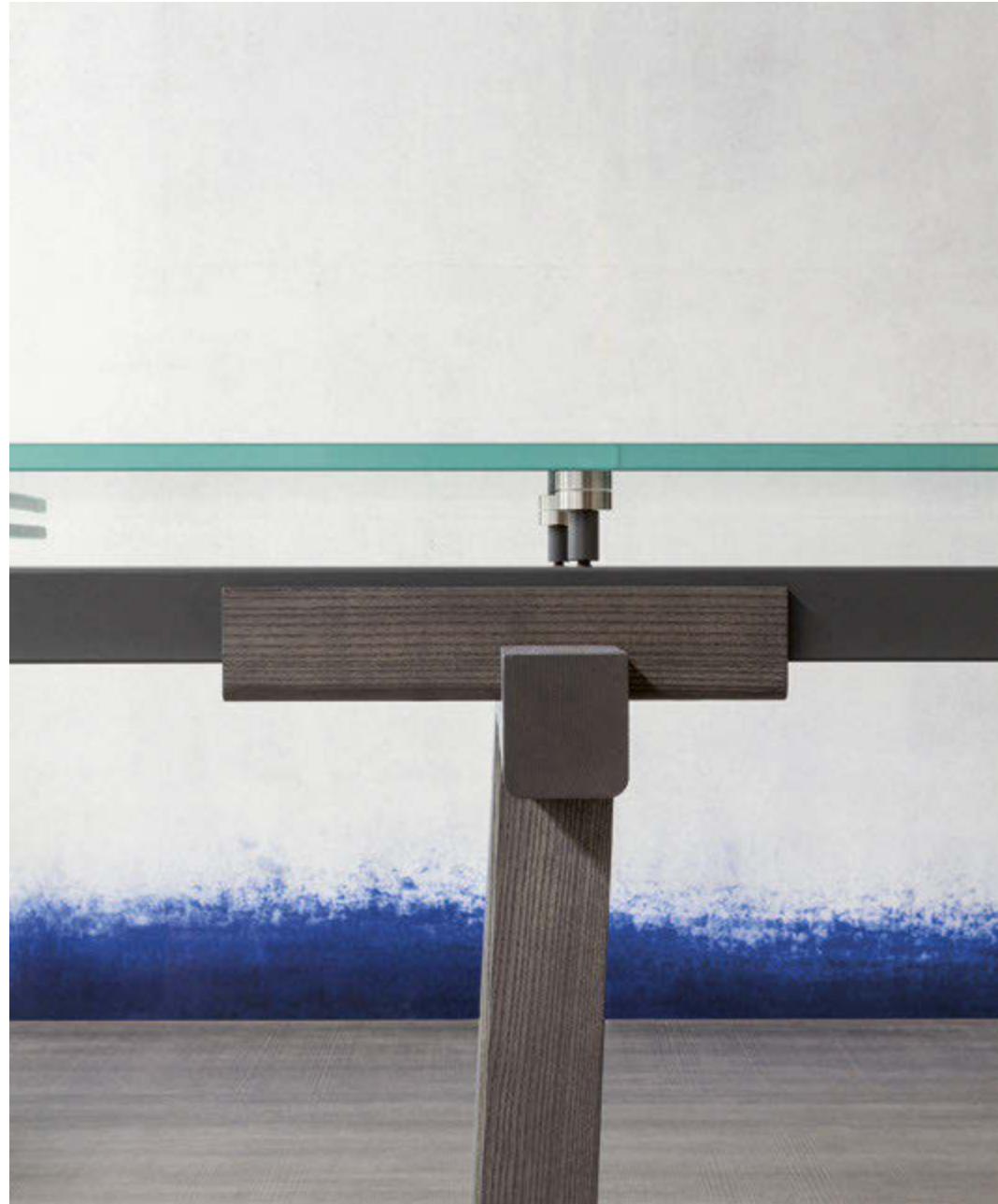

Tracks Alain Gilles
Tavolo. Table. Tisch. Table.

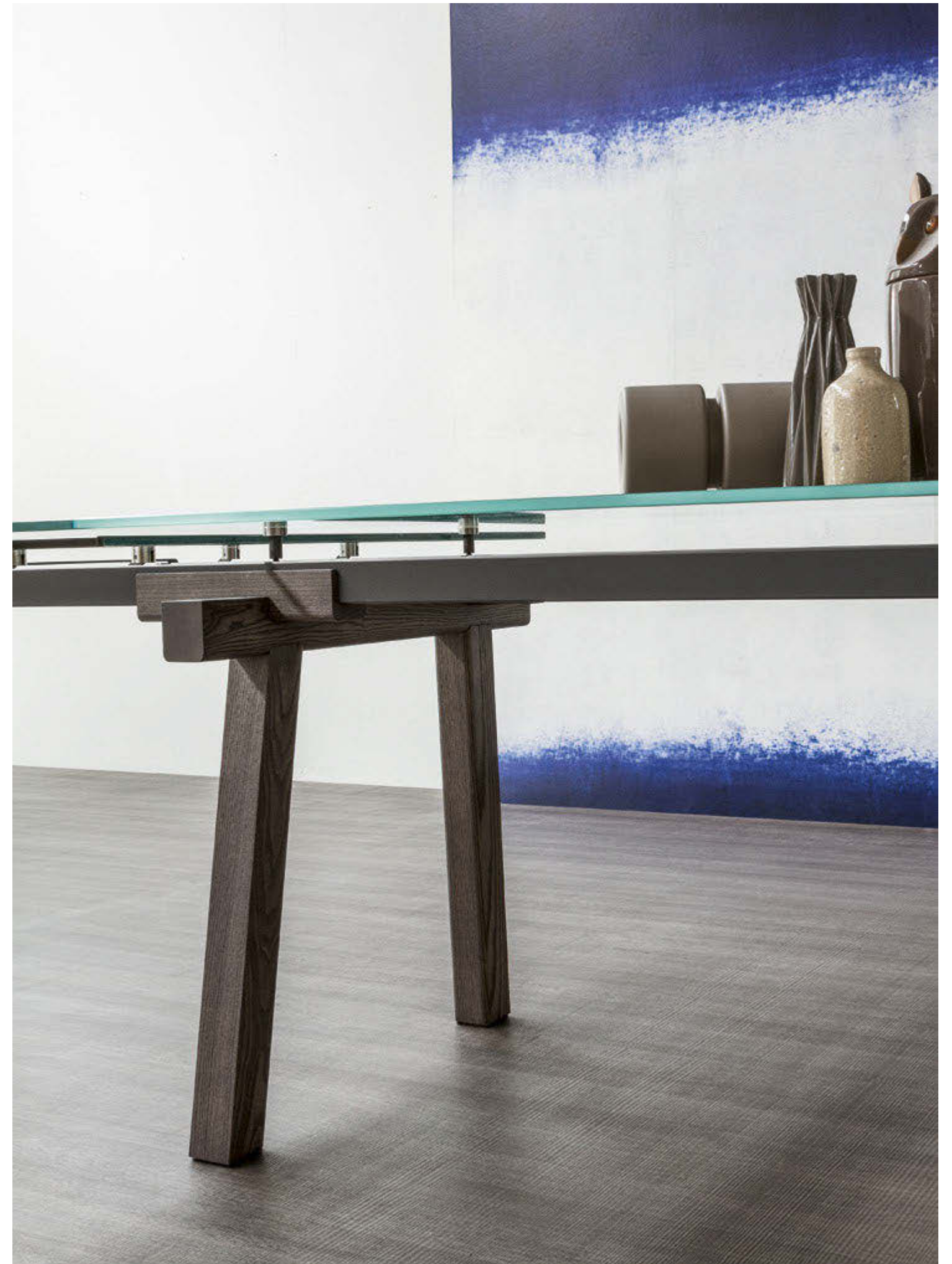

Greeny

Greeny nasce dall'interesse e dalla passione per i materiali naturali, quali il legno massello, scelto per la base ellittica, ed il marmo con cui è realizzato il piano. Ha un'immagine che esprime personalità e si presta ad essere abbinato ad arredi dai vari riferimenti stilistici.

En Greeny comes from an interest and passion for natural materials, such as solid wood, chosen due to its elliptical base and the marble used for making the top. It has an image that expresses personality and lends itself to being combined with furnishings that have various style references.

De Greeny entstand aus der Begeisterung für natürliche Materialien. Das ovale Gestell besteht aus massivem Holz, die Tischplatte aus Marmor. Sein charakterstarkes Design lässt sich schön mit den unterschiedlichsten Einrichtungsstilen kombinieren.

Fr Greeny naît de l'intérêt et de la passion pour les matériaux naturels comme le bois massif, choisi pour la base elliptique, et le marbre dont est constitué le plateau. Une table pleine de personnalité mais facile à marier avec des meubles de styles différents.



Greeny Gino Carollo
Tavolo. Table. Tisch. Table.

Marmo Carrara opaco / frassino grigio
Mat Carrara marble / grey ash
Matt Carrara Marmor / Eschenholz Grau
Marbre Carrara opaque / frêne gris





Greeny Gino Carollo
Tavolo. Table. Tisch. Table.
Marmo Calacatta lucido / noce americano
Glossy Calacatta marble / American walnut
Glänzend Calacatta Marmor / Amerikaner Nussbaum
Sheryl Giuseppe Viganò
Sedia. Chair. Stuhl. Chaise.
Marbre Calacatta brillant / noyer américain



Greeny Gino Carollo
Tavolo. Table. Tisch. Table.
Sheryl Giuseppe Viganò
Sedia. Chair. Stuhl. Chaise.

Marmo Emperador lucido / noce americano
Glossy Emperador marble / American walnut
Glänzend Emperador Marmor / Amerikaner Nussbaum
Marbre Emperador brillant / noyer américain



Greeny Gino Carollo
Tavolo. Table. Tisch. Table.
Sheryl Giuseppe Viganò
Sedia. Chair. Stuhl. Chaise.

Marmo Marquinia lucido / noce americano
Glossy Marquinia marble / American walnut
Glänzend Marquinia Marmor / Amerikaner Nussbaum
Marbre Marquinia brillant / noyer américain



Greeny Gino Carollo
Tavolo. Table. Tisch. Table.
Napi Bartoli Design
Sedia. Chair. Stuhl. Chaise.

Cristallo trasparente / noce americano
Transparent glass / American walnut
Klarglas / Amerikaner Nussbaum
Cristal transparent / noyer américain





Medley

Un tavolo moderno ed elegante, fortemente caratterizzato dalla fusione di stili, geometrie e materiali. Le gambe sono collegate attraverso un elemento longitudinale centrale; la linea del piano nasce dalla fusione di due forme geometriche, il rettangolo e l'ovale, dando vita ad una forma nuova e originale.

En A modern and elegant table, strongly characterised by a blend of styles, geometries and materials. The legs are connected through a central longitudinal element and the outline of the table top stems from the merger of two geometric shapes, namely the rectangle and the oval, giving rise to a new and original shape.

Fr Une table moderne et élégante, fortement caractérisée par la fusion des styles, des géométries et des matériaux. Les pieds sont reliés au centre par un élément longitudinal ; la ligne du plateau naît, quant à elle, de la fusion de deux formes géométriques, le rectangle et l'ovale, donnant naissance à une forme nouvelle et originale.

De Der moderne und elegante Tisch besticht durch einen gelungenen Mix unterschiedlicher Stilrichtungen, Formen und Materialien. Die Beine sind durch ein langgezogenes zentrales Element miteinander verbunden. Das Design der Tischplatte ist Resultat der Verschmelzung zweier unterschiedlicher geometrischer Figuren – eines Rechtecks und eines Ovals – aus der eine neue, originelle Form entsteht.

Medley Alessandro Busana
Tavolo. Table. Tisch. Table.

Marmo Emperador lucido / noce americano
Glossy Emperador marble / American walnut
Glänzend Emperador Marmor / Amerikaner Nussbaum
Marbre Emperador brillant / noyer américain



Medley Alessandro Busana
Tavolo. Table. Tisch. Table.

By Bartoli Design
Sedia. Chair. Stuhl. Chaise.

Pag. 150-151, 152, 153
Marmo Calacatta opaco / frassino grigio
Mar Calacatta marble / grey ash
Matt Calacatta Marmor / Eschenholz Grau
Marbre Calacatta opaque / frêne gris



Medley Alessandro Busana
Tavolo. Table. Tisch. Table.

By Bartoli Design
Sedia. Chair. Stuhl. Chaise.





Medley Alessandro Busana
 Tavolo. Table. Tisch. Table.
By Bartoli Design
 Sedia. Chair. Stuhl. Chaise.

Marmo Emperador lucido / noce americano
 Glossy Emperador marble / American walnut
 Glänzend Emperador Marmor / Amerikaner Nussbaum
 Marbre Emperador brillant / noyer américain





Medley Alessandro Busana
 Tavolo. Table. Tisch. Table. Laccato bianco opaco / noce americano
 Mat white lacquered / American walnut
By Bartoli Design Weiss matt lackiert / Amerikaner Nussbaum
 Sedia. Chair. Stuhl. Chaise. Laqué blanc opaque / noyer américain

Twice

Un tavolo dalle geometrie rigorose, caratterizzato da uno spirito pratico e funzionale. Nella versione allungabile, grazie allo spostamento laterale, le gambe si collocano all'estremità del piano e non intralciano la seduta degli ospiti; la prolunga permette di aumentare con facilità la lunghezza del piano.

En A table with rigorous geometries, with a practical and functional spirit. In the extending version, thanks to the side movement, the legs are positioned at the end of the table, without getting in the way of the seated guests; the extension makes it possible to increase the length of the table top easily.

De Streng geometrisch und dabei vor allem eines – praktisch. Wird die Tischplatte der ausziehbaren Ausführung verlängert, rücken auch die Tischbeine entsprechend nach außen, so dass alle Gäste bequem sitzen können. Mithilfe der Verlängerung lässt sich die Auflagefläche so im Handumdrehen vergrößern.

Fr Une table aux géométries rigoureuses, caractérisée par un esprit pratique et fonctionnel. Dans la version extensible, grâce à leur déplacement latéral, les pieds se placent aux extrémités du plateau et ne gênent pas la chaise des hôtes ; la rallonge permet d'augmenter facilement la longueur du plateau.

Pag. 159, 160, 161
Rovere termotrattato
Heat-treated oak
Thermo-behandelte Eiche
Rouvre traité thermiquement

Twice Mauro Lipparini
Tavolo. Table. Tisch. Table.





Twice Mauro Lipparini Tavolo. Table. Tisch. Table.
Tip Toe Mauro Lipparini Sedia. Chair. Stuhl. Chaise.





Twice Mauro Lipparini
Tavolo. Table. Tisch. Table.
Skip Arm Karim Rashid
Sedia. Chair. Stuhl. Chaise.

Cristallo acidato bianco / laccato bianco opaco
White acid-treated glass / mat white lacquered
Geätztes Glas Weiss / Weiss matt lackiert
Cristal traité à l'acide blanc / laqué blanc opaque

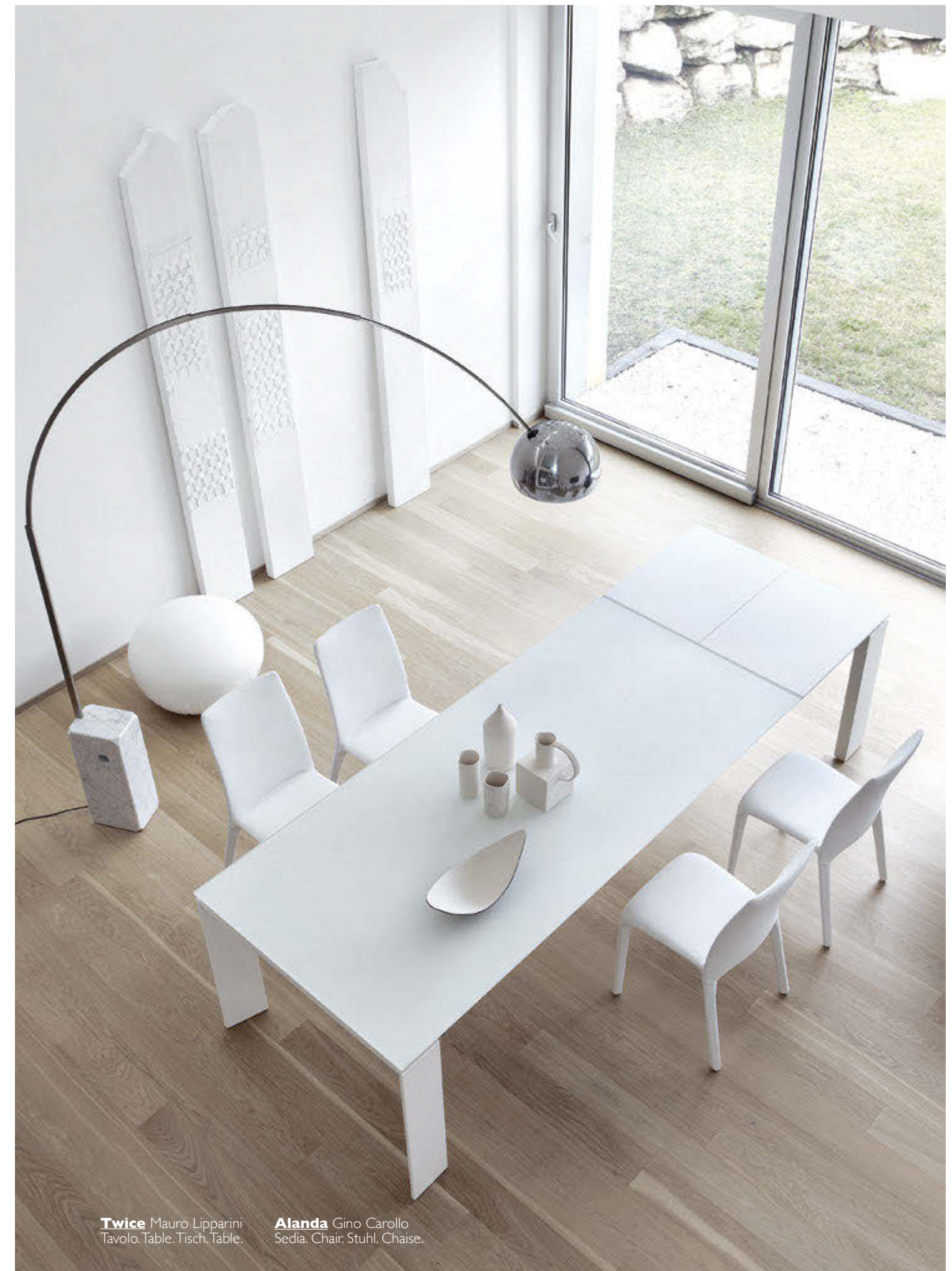

Twice Mauro Lipparini
Tavolo. Table. Tisch. Table.
Alanda Gino Carollo
Sedia. Chair. Stuhl. Chaise.



Twice Mauro Lipparini
Tavolo. Table. Tisch. Table.

Tip Toe Mauro Lipparini
Sedia. Chair. Stuhl. Chaise.

Cristallo acidato nero / noce Canaletto
Black acid-treated glass / Canaletto walnut
Geätztes Glas Schwarz / Nussbaum Canaletto
Cristal traité à l'acide noir / noyer Canaletto

Flag

La cura dei dettagli progettuali è ciò che caratterizza Flag, un tavolo di particolare importanza visiva. Le gambe, disponibili in diverse essenze, sono impreziosite da un profilo in acciaio verniciato opaco. Oltre alla versione fissa, Flag è realizzato anche nella versione allungabile: grazie allo spostamento laterale, le gambe si collocano all'estremità del piano.

En A focus on design details is what characterises Flag, a table with a particularly important visual aspect. The legs, which are available in different essences, are embellished by a matt painted steel profile. In addition to the fixed version, Flag is also available in the extending version: thanks to the side movement, the legs are positioned at the end of the table.

De Design mit Liebe zum Detail. Flag ist ein Tisch mit einprägsamer, starker Optik. Die in verschiedenen Holzarten erhältlichen Tischbeine werden durch ein matt lackiertes Stahlprofil zusätzlich aufgewertet. Flag ist sowohl mit ausziehbarer als auch nicht ausziehbarer Tischplatte verfügbar. Beim Ausziehen des Tisches rücken auch die Tischbeine entsprechend nach außen.

Fr La table Flag se distingue sans aucun doute par son impact visuel mais aussi par le soin apporté aux détails et ce, dès la phase conceptuelle. Disponibles en différentes essences, les pieds sont ornés d'un filet en acier verni mat. En plus de la version fixe, Flag existe également en version extensible où, grâce au déplacement latéral, les pieds se placent aux extrémités du plateau.



Flag Mauro Lipparini
Tavolo. Table. Tisch. Table.

Razor X Mauro Lipparini
Sedia. Chair. Stuhl. Chaise.

Pag. 166, 167, 168-169
Cristallo acidato bianco / frassino grigio / arancio
White acid-treated glass / grey ash / orange
Geätztes Weiss Glas / Eschenholz Grau / Orange
Cristal traité à l'acide blanc / frêne gris / orange

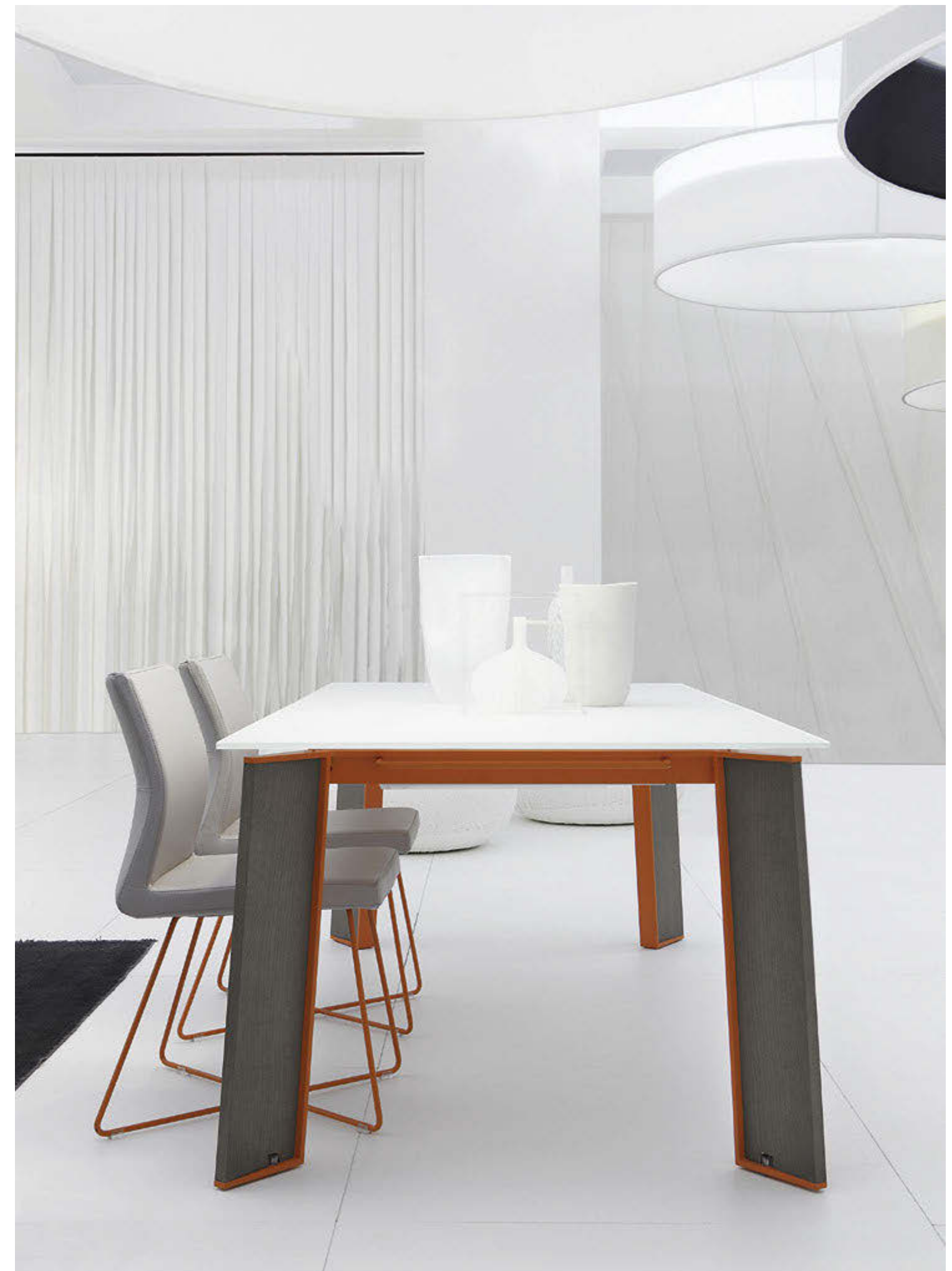



Flag Mauro Lipparini
Tavolo. Table. Tisch. Table.
Blues Dondoli e Poggi
Sedia. Chair. Stuhl. Chaise.

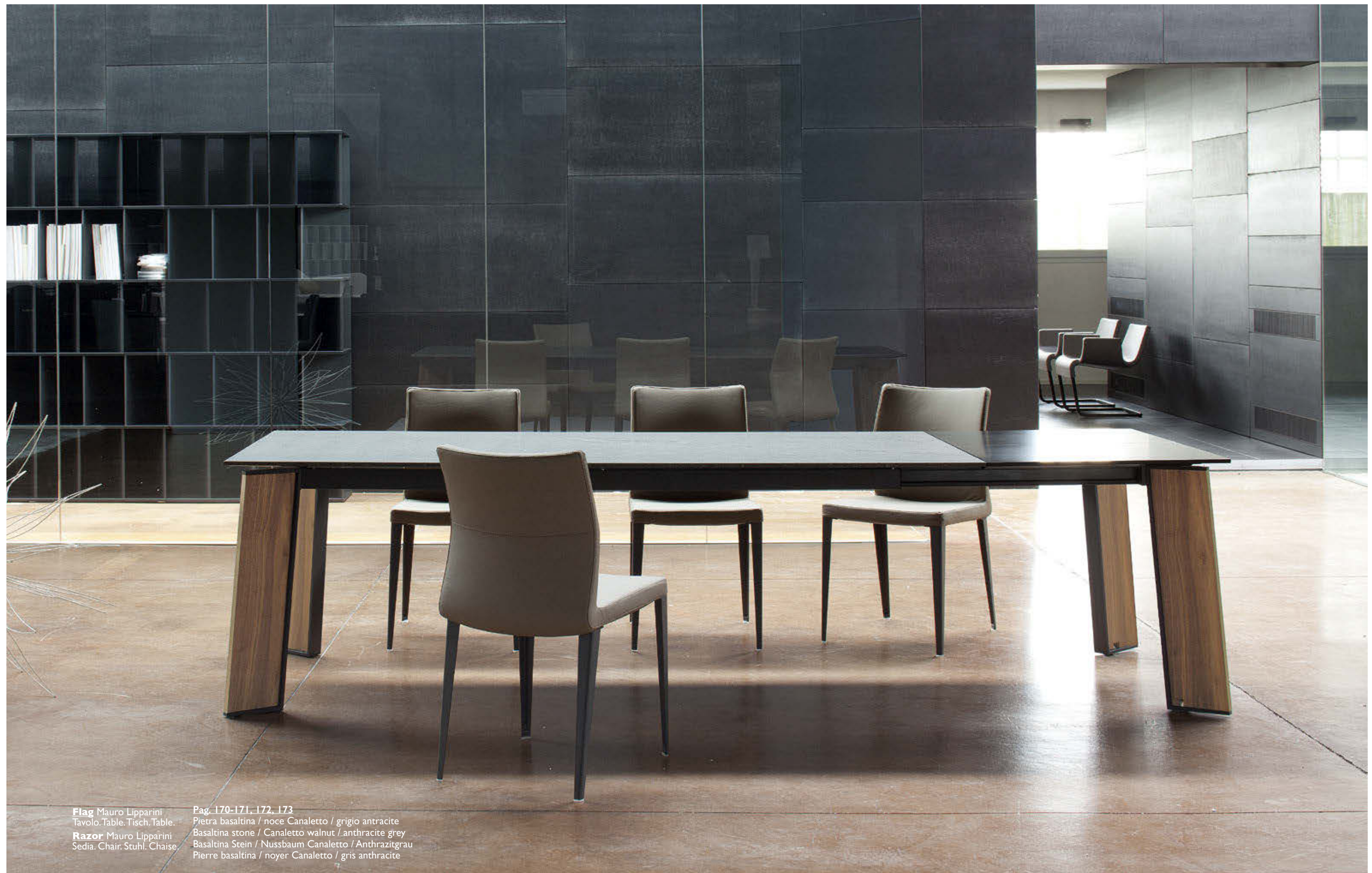

Flag Mauro Lipparini
Tavolo. Table. Tisch. Table.

Razor Mauro Lipparini
Sedia. Chair. Stuhl. Chaise

Pag. 170-171, 172, 173

Pietra basaltina / noce Canaletto / grigio antracite
Basaltina stone / Canaletto walnut / anthracite grey
Basaltina Stein / Nussbaum Canaletto / Anthrazitgrau
Pierre basaltina / noyer Canaletto / gris anthracite



Flag Mauro Lipparini
Tavolo. Table. Tisch. Table.

Razor Mauro Lipparini
Sedia. Chair. Stuhl. Chaise.

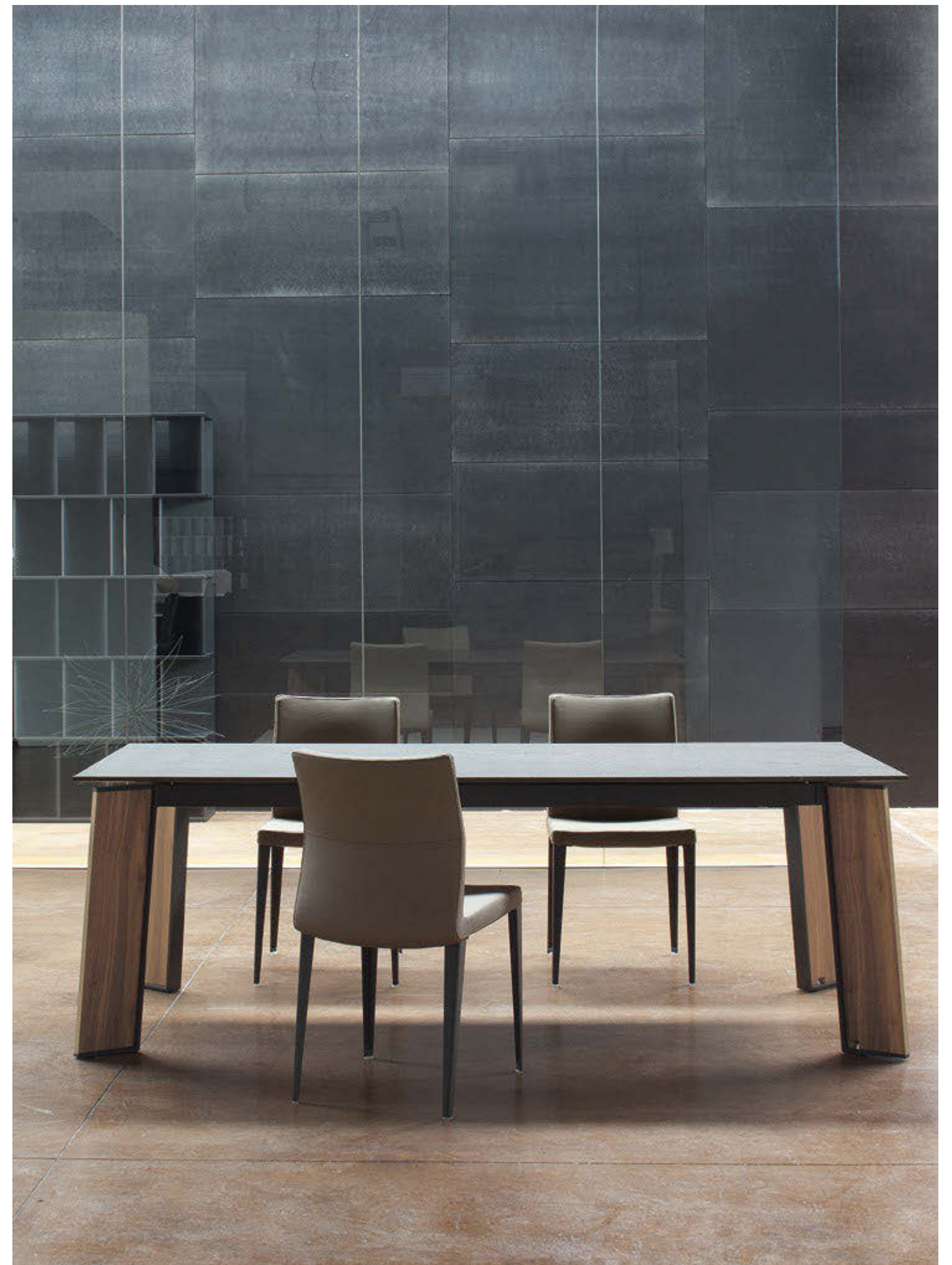

Gap

Gap significa apertura, distanza, spazio. L'elemento distintivo di Gap, infatti, è rappresentato dalle gambe, costituite da due "lame" metalliche che si aprono gradatamente verso l'alto. Nel complesso, il tavolo è molto lineare, per dare massimo risalto al design delle gambe: la base metallica che sostiene il piano è nascosta dal piano stesso, di modo che la linea di Gap risulti semplice ed essenziale.

En Gap means opening, distance and space. In fact, the distinguishing feature of Gap lies in the legs, which consist of two metal "blades" that gradually open out upwards. As a whole, the table is very linear, giving maximum emphasis to the design of the legs. The metal base which supports the table top is hidden by the top itself, so that Gap's line is simple and essential.

De Gap bedeutet Öffnung, Abstand, Freiraum. Tatsächlich besticht Gap durch die Form seiner Beine, zwei „Klingen“ aus Metall, die sich nach oben öffnen. Sein lineares Gesamtbild bringt das ungewöhnliche Design der Beine noch stärker zur Geltung. Das Metallgestell, das die Tischplatte trägt, wird von dieser verdeckt und garantiert so eine klare und schlichte Linienführung.

Fr Gap signifie ouverture, distance, espace. L'élément distinctif de Gap est en effet représenté par les pieds, constitués de deux « lames » métalliques qui s'ouvrent graduellement vers le haut. Dans l'ensemble, la table est très linéaire pour mettre en valeur le design des pieds : la base métallique qui soutient le plateau est dissimulée par ce dernier, de manière à conserver une ligne simple et essentielle.

Gap Alain Gilles
Tavolo. Table. Tisch. Table.
Junan Bartoli Design
Sedia. Chair. Stuhl. Chaise.

Pag. 174, 175, 176-177
Rovere grigio antracite / grigio antracite
Anthracite grey oak / anthracite grey
Eiche Anthrazitgrau / Anthrazitgrau
Rouvre gris anthracite / gris anthracite





Gap Alain Gilles
Tavolo. Table. Tisch. Table.

Junan Bartoli Design
Sedia. Chair. Stuhl. Chaise.



Gap Alain Gilles
Tavolo. Table. Tisch. Table.

My Time Dondoli e Poggi
Sedia. Chair. Stuhl. Chaise.

Noce americano / corten
American walnut / corten
Amerikaner Nussbaum / Corten
Noyer américain / corten



Gap Alain Gilles
Tavolo. Table. Tisch. Table.
Junan Bartoli Design
Sedia. Chair. Stuhl. Chaise.

Cristallo acidato nero / grigio antracite
Black acid-treated glass / anthracite grey
Geätztes Glas Schwarz / Anthrazitgrau
Cristal traité à l'acide noir / gris anthracite

Welded

Le gambe del tavolo Welded sono tagliate laser poi, come indicato dal nome stesso, saldate tra di loro ed infine verniciate. Il piano è di forma rettangolare: estrema linearità delle forme, essenziali e rigorose, e scelta progettuale che affida ai materiali di finitura l'interpretazione dell'oggetto.

En The legs of the Welded table are laser cut and then, as indicated by the name itself, welded together and then painted. The top is rectangular - the ultimate linearity of the essential and simple shapes, a design choice that entrusts the finishing materials with the interpretation of the object.

De Die Tischbeine von Welded werden mit dem Laser geschnitten und anschließend, wie bereits der Name verrät, miteinander verschweißt und lackiert. Die Tischplatte ist rechteckig, insgesamt regieren kompromisslos lineare, schlichte, strenge Formen. Für ein Design, das der individuellen Ausführung der Materialien die konkrete Interpretation des Gegenstands überlässt.

Fr Les pieds de la table Welded sont découpés au laser puis, comme le nom de la table l'indique, soudés entre elles avant d'être vernies. Le plateau est de forme rectangulaire, ce qui fait ressortir la linéarité des formes, essentielles et rigoureuses et un choix de conception qui confie aux matériaux de finition l'interprétation de l'objet.

Welded Alain Gilles
Tavolo. Table. Tisch. Table.

Marmo Carrara opaco / rosso brillante
Mat Carrara marble / luminous red
Matt Carrara Marmor / Leuchtrot
Marbre Carrara opaque / rouge brillant





Welded Alain Gilles
Tavolo. Table. Tisch. Table.
Rest Dondoli e Poggi
Sedia. Chair. Stuhl. Chaise.

Marmo Carrara opaco / grigio antracite
Mat Carrara marble / anthracite grey
Matt Carrara Marmor / Anthrazitgrau
Marbre Carrara opaque / gris anthracite



Welded Alain Gilles
Tavolo. Table. Tisch. Table.
Rovere grigio antracite / grigio antracite
Anthracite grey oak / anthracite grey
Eiche Anthrazitgrau / Anthrazitgrau
Rest Dondoli e Pocci
Sedia. Chair. Stuhl. Chaise.
Rouvre gris anthracite / gris anthracite



Welded Alain Gilles
Tavolo. Table. Tisch. Table.
My Time Dondoli e Pocci
Sedia. Chair. Stuhl. Chaise.

Match

Un interessante equilibrio tra piano e struttura: Match è un tavolo allungabile, le cui leggere gambe in legno si ispirano alla forma di un fiammifero, da cui prende il nome. Il piano è impreziosito da un profilo in tinta con il piano stesso.

En An interesting balance between the top and the structure. Match is an extending table, which is as light as a match, evoked by its name due to the shape of its wooden legs. The top is embellished by a profile that matches the colour of the top.

De Tischplatte und Tischbeine bilden zusammen ein auf interessante Weise harmonisches Ganzes. Der ausziehbare Tisch Match lässt dabei an die Leichtigkeit eines Streichholzes denken. Wie auch sein Name, den er der Form seiner Holztischbeine verdankt. Die Tischplatte ziert ein Profil in derselben Farbe der Auflagefläche.

Fr Un équilibre intéressant entre plateau et structure : Match est une table extensible, caractérisée par la légèreté d'une allumette (d'où son nom) dont s'inspire la forme des pieds en bois. Le plateau est orné d'un filet assorti.



Match Mauro Lipparini
Tavolo. Table. Tisch. Table.

Kamar Mauro Lipparini
Sedia. Chair. Stuhl. Chaise.



Pag. 188, 189, 190-191, 192, 193
Cristallo acidato bianco / frassino tinto noce
White acid-treated glass / walnut painted ash
Geätztes Glas Weiss / Esche nussbaumfarbig lackiert
Cristal traité à l'acide blanc / frêne teinté noyer



Match Mauro Lipparini
Tavolo. Table. Tisch. Table.

Kamar Mauro Lipparini
Sedia. Chair. Stuhl. Chaise.



Match Mauro Lipparini
Tavolo. Table. Tisch. Table.



Still

Still è una collezione di tavoli fissi, diversi per forma del piano e dimensioni, caratterizzati da gambe coniche in cemento. Un'architettura domestica intensa ed evocativa, che interpreta in modo originale la storia del design.

En Still is a collection of fixed tables, which differ in the shape of their table top and size, characterized by tapered concrete legs. An intense and evocative domestic architecture, which interprets the history of design originally.

De Die Kollektion Still umfasst eine Reihe nicht ausziehbarer Tische mit verschiedenen Tischplatten in unterschiedlichen Größen. Ihnen allen gemein sind die kegelförmigen Tischbeine aus Zement. Das Ergebnis ist eine architektonisch anmutende, suggestive Optik, eine originelle Neuinterpretation der Geschichte des Designs.

Fr Still est une collection de tables fixes aux pieds coniques qui se distinguent les unes des autres par la forme et les dimensions du plateau. Une architecture domestique intense et évocatrice, qui interprète de façon originale l'histoire du design.



Still Bartoli Design
Tavolo. Table. Tisch. Table.
By Bartoli Design
Sedia. Chair. Stuhl. Chaise.

Pag. 194, 195, 196-197
Noce americano / cemento
American walnut / cement
Amerikaner Nussbaum / Sichtbeton
Noyer américain / ciment





Still Bartoli Design
Tavolo. Table. Tisch. Table.

Kamar Bartoli Design
Sedia. Chair. Stuhl. Chaise.



Still Bartoli Design Laccato bianco opaco / cemento
 Tavolo. Table. Tisch. Table. Mat white lacquered/ cement
Kamar Bartoli Design Weiss matt lackiert / Sichtbeton
 Sedia. Chair. Stuhl. Chaise. Laqué blanc opaque / ciment



Vanessa

Le gambe, dalla evocativa forma a farfalla, sono realizzate in multilaminare stratificato di legno; il piano in cristallo trasparente è disponibile in diverse forme e dimensioni. Vanessa è un tavolo che riesce a regalare intensità all'ambiente domestico: una scultura dedicata ai riti quotidiani.

En The legs, which are an evocative butterfly shape, are made of multilaminar wood veneer. The transparent glass top is available in different shapes and sizes. Vanessa is a table that succeeds in giving intensity to the domestic environment with a structure dedicated to daily rituals.

De Die schmetterlingsförmigen Tischbeine bestehen aus Schichtholz, die transparente Glastischplatte ist in unterschiedlichen Formen und Größen erhältlich. Der Tisch Vanessa verleiht Wohnräumen eine eigene Intensität – Skulptur und Alltagsgegenstand in einem.

Fr Les pieds sont constitués de panneaux multiplis disposés de manière à évoquer les ailes d'un papillon. Le plateau en verre transparent est disponible en différentes formes et dimensions. Sculpture dédiée aux rituels du quotidien, Vanessa est une table en mesure d'apporter de l'intensité à l'espace domestique.

Vanessa Bartoli Design
Tavolo. Table. Tisch. Table.

Lamina Mauro Lipparini
Sedia. Chair. Stuhl. Chaise.

Pag. 201, 202-203, 204, 205

Cristallo trasparente / multilaminare tinto noce
Transparent glass / walnut coloured multilaminar
Klarglas / Multilaminieret nussbaumfarbig
Cristal transparent / multilaminaire teinté noyer





Vanessa Bartoli Design
Tavolo. Table. Tisch. Table.
My Time Dondoli e Pocci
Sedia. Chair. Stuhl. Chaise.



Vanessa Bartoli Design
Tavolo. Table. Tisch. Table.

My Time Dondoli e Pocci
Sedia. Chair. Stuhl. Chaise.

Mille

La trasparenza del piano in cristallo unito alla presenza delle numerose gambe in acciaio, variabili secondo le dimensioni del piano, per garantire massima stabilità e coerenza visiva. Mille è un tavolo fisso che sembra possedere tutta l'armonia e la dinamicità di un corpo trasparente in movimento.

En The transparency of the glass top along with the numerous steel legs, according to the size of the top, guarantee maximum stability and visual coherence. Mille is a fixed table that seems to have all the harmony and dynamism of a transparent body in motion.

De Die Transparenz der Glasplatte wird hier gekonnt mit dem Bild der zahlreichen Tischbeine aus Stahl kombiniert. Deren Anzahl variiert je nach Größe der Tischplatte, um in jedem Fall maximale Stabilität und eine ausgewogene Optik zu gewährleisten. Der nicht ausziehbare Tisch Mille berührt den Betrachter so mit der Harmonie und Dynamik eines transparenten Körpers in Bewegung.

Fr La transparence du plateau en cristal associée à la présence de nombreux pieds en acier (leur nombre dépend de la taille du plateau) garantit une stabilité optimale et une cohérence visuelle. Mille est une table fixe qui semble posséder toute l'harmonie et le dynamisme d'un corps transparent en mouvement.



Mille Bartoli Design
Tavolo. Table. Tisch. Table.

Marta
Sedia. Chair. Stuhl. Chaise.

Pag. 206, 207, 208-209, 210, 211
Cristallo trasparente / cromato
Transparent glass / chromed
Klarglas / Verchromt
Cristal transparent / chromé





Mille Bartoli Design
Tavolo. Table. Tisch. Table.
Venere Bartoli Design
Sedia. Chair. Stuhl. Chaise.



Mille Bartoli Design
Tavolo. Table. Tisch. Table.
Alanda Dondoli e Pocci
Sedia. Chair. Stuhl. Chaise.



Mille Bartoli Design
Tavolo. Table. Tisch. Table.
Marta
Sedia. Chair. Stuhl. Chaise.

Tom

Tom è un tavolo allungabile che attribuisce una notevole centralità visiva agli elementi strutturali in acciaio, quali gambe e binari di scorrimento. Le due prolunghe laterali sono indipendenti e aumentano notevolmente la superficie d'appoggio, mantenendo un'ottima stabilità e solidità.

En Tom is an extending table that gives substantial visual centrality to the structural steel elements, such as the legs and sliding tracks. The two side extensions are independent and significantly increase the support surface while retaining maximum stability and solidity.

Fr Tom est une table extensible qui met en valeur les éléments structurels en acier tels que les pieds et les rails. Les deux rallonges latérales sont indépendantes et augmentent considérablement la surface d'appui, en conservant une excellente stabilité et solidité.

De Tom ist ein ausziehbarer Tisch, bei dem das Gestell aus Stahl, die Tischbeine und Ausziehschienen, visuell klar im Mittelpunkt stehen. Mithilfe der beiden separaten seitlichen Verlängerungen kann die Auflagefläche zudem jederzeit deutlich vergrößert werden, ohne dadurch die Stabilität und Standfestigkeit des Tisches zu beeinträchtigen.

Pag. 213, 214-215

Cristallo trasparente / grigio antracite
Transparent glass / anthracite grey
Klarglas / Anthrazitgrau
Cristal transparent / gris antracite

Tom
Tavolo. Table. Tisch. Table.





Tom
Tavolo. Table. Tisch. Table.



Tom
Tavolo. Table. Tisch. Table.
Marta
Sedia. Chair. Stuhl. Chaise.

Pag. 216, 217, 218-219
Cristallo trasparente / acciaio inox lucido
Transparent glass / glossy stainless steel
Klarglas / Edelstahl glänzend
Cristal transparent / acier inox brillant





Tom
Tavolo. Table. Tisch. Table.

Marta
Sedia. Chair. Stuhl. Chaise.

Sol

Sol è un tavolo fisso o allungabile innovativo e di grande suggestione visiva. Grazie alla forma slanciata delle gambe in alluminio e alla essenzialità del piano, disponibile in cristallo oppure in Doluflex, esprime un'elegante leggerezza di forme.

En Sol is an innovative fixed or extending table with great visual appeal. Thanks to the slender shape of its aluminium legs and the elementary shape of the top, which is available in glass or Doluflex, it expresses an elegant lightness of shapes.

Fr Sol est une table fixe ou extensible, innovante et d'un très grand impact visuel. Grâce à la forme élancée des pieds en aluminium et au caractère essentiel du plateau, disponible en cristal ou en Doluflex, Sol présente des formes légères et élégantes.

De Sol wird sowohl mit ausziehbarer als auch nicht ausziehbarer Tischplatte angeboten und besticht insbesondere durch seine suggestive Optik. Die schlanken Aluminiumbeine und die schlichte Tischplatte aus Glas oder Doluflex verleihen dem Tisch außergewöhnliche Leichtigkeit und Eleganz.



Sol Bartoli Design
Tavolo. Table. Tisch. Table.

Doluflex grigio antracite / grigio antracite
Anthracite grey Doluflex / anthracite grey
Doluflex Anthrazitgrau / Anthrazitgrau
Doluflex gris anthracite / gris antracite





Sol Bartoli Design
Tavolo. Table. Tisch. Table.
Blues Dondoli e Poggi
Sedia. Chair. Stuhl. Chaise.

Cristallo acidato bianco / bianco
White acid-treated glass / white
Geätztes Glas Weiss / Weiss
Cristal traité à l'acide blanc / blanc



Sol Bartoli Design
Tavolo. Table. Tisch. Table.

Pag. 224, 225, 226-227
Doluflex grigio antracite / grigio antracite
Anthracite grey Doluflex / anthracite grey
Doluflex Anthrazitgrau / Anthrazitgrau
Doluflex gris anthracite / gris anthracite





Sol Bartoli Design
Tavolo. Table. Tisch. Table.

Menù

Il tavolo è Menù, dedicato ai momenti di piacere e convivialità: pratico e leggero, sorprende per il suo gusto e per le atmosfere che sa creare ed è sempre pronto per aggiungere posti a tavola. Dotato di prolunghe manuali indipendenti che permettono di aumentare la superficie d'appoggio, Menù è allungabile a seconda delle esigenze.

En The Menu table, dedicated to times of pleasure and socialising, is practical and light. It surprises with its taste and the atmospheres it can create and is always ready to add places at the table. Equipped with independent manual extensions that increase the support surface, Menu can be extended according to requirements.

De Der Tisch Menù lässt uns die schönen Momente des Beisammenseins so richtig genießen. Praktisch und „leicht“ überrascht er mit geschmackvollem Design und schafft zugleich eine angenehme Atmosphäre bei Tisch. Auch eventuell zusätzlich benötigte Sitzplätze sind für ihn kein Problem: Mithilfe der separaten manuellen Verlängerungen lässt sich die Auflagefläche von Menù jederzeit je nach Bedarf vergrößern.

Fr La table Menù est dédiée à nos moments de plaisir et de convivialité: pratique et légère, elle surprend par son goût et les atmosphères qu'elle sait créer et sa capacité à pouvoir toujours ajouter de la place à table. Menù est équipée de rallonges manuelles indépendantes qui permettent d'augmenter la surface d'appui en fonction des besoins.

Menù Bartoli Design
Tavolo. Table. Tisch. Table.

Kayla up Dondoli e Pocci
Sedia. Chair. Stuhl. Chaise.

Pag. 229, 230-231

Cristallo acidato grigio antracite / grigio antracite
Anthracite grey acid-treated glass / anthracite grey
Geätztes Glas Anthrazitgrau / Anthrazitgrau
Cristal traité à l'acide gris anthracite / gris anthracite





Menù Bartoli Design
Tavolo. Table. Tisch. Table.

Kayla up Dondoli e Poggi
Sedia. Chair. Stuhl. Chaise.



Menù Bartoli Design
 Tavolo. Table. Tisch. Table.
 Cristallo acidato grigio antracite / grigio antracite
 Anthracite grey acid-treated glass / anthracite grey
 Geätztes Glas Anthrazitgrau / Anthrazitgrau
 Cristal traité à l'acide gris anthracite / gris anthracite





Menù Bartoli Design
Tavolo. Table. Tisch. Table.

Cristallo acidato tortora / tortora
Dove grey acid-treated glass / dove grey
Geätztes Glas Taubengrau / Taubengrau
Cristal traité à l'acide gris tourterelle / gris tourterelle



Menù Bartoli Design
 Tavolo. Table. Tisch. Table.
 Cristallo acidato bianco / bianco
 White acid-treated glass / white
 Geätztes Glas Weiss / Weiss
 Cristal traité à l'acide blanc / blanc

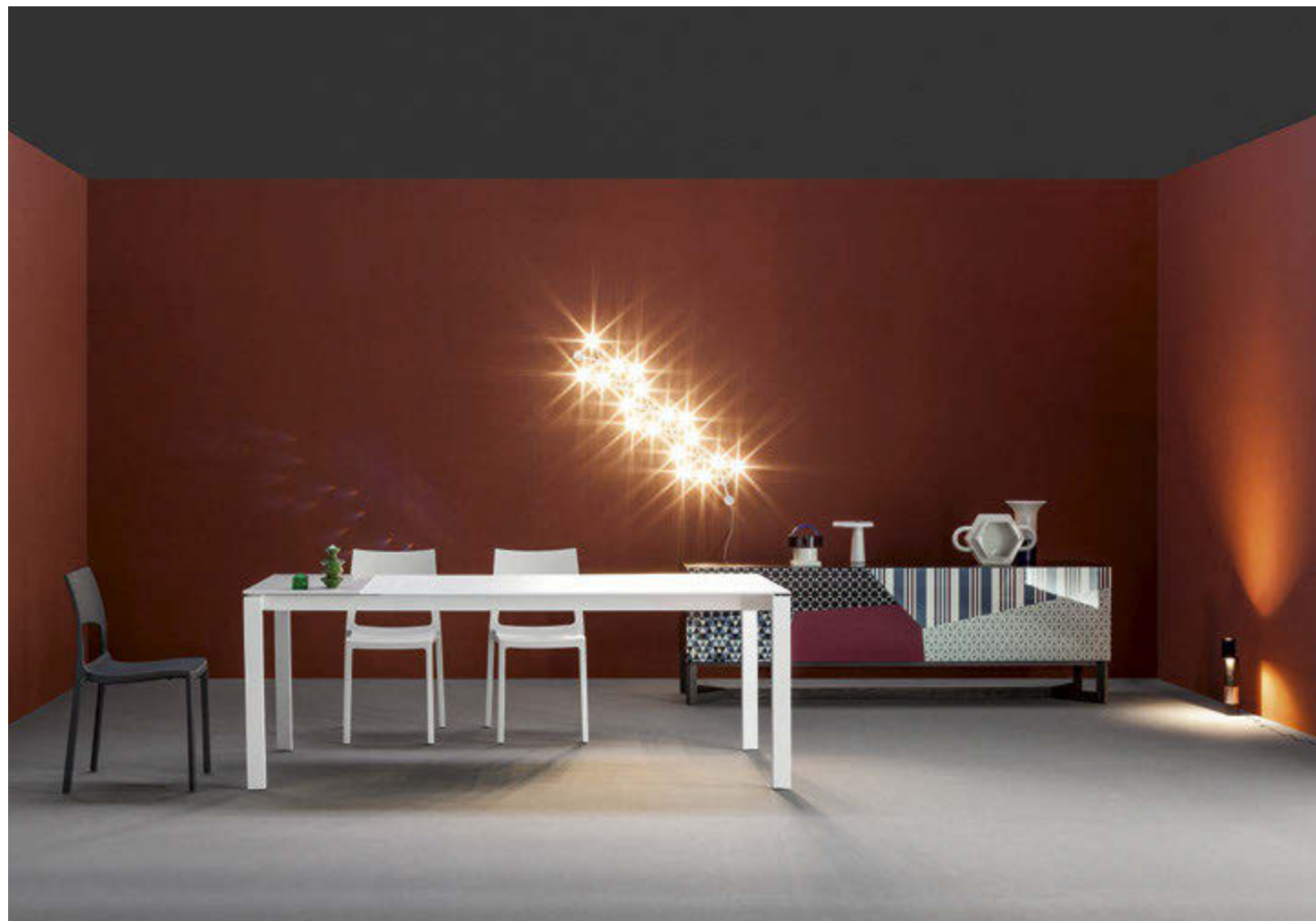

Kime

Kime è un tavolo caratterizzato da leggerezza di forme, discrezione ed eleganza, particolarmente indicato per chi desidera la praticità del piano allungabile senza rinunciare al design. È possibile aumentare con facilità la lunghezza del piano grazie ad un semplice scorrimento laterale delle gambe e ad una o due prolunghe.

En Kime is a table marked by light shapes, discretion and elegance, particularly suitable for anyone looking for the practicality of an extending top without sacrificing the design element. The top can be easily extended by simply sliding the legs sideways and adding one or more extensions.

De Der Tisch Kime besticht durch seine Leichtigkeit, respektvolle Zurückhaltung, Eleganz. Die ideale Lösung für alle, die einen ausziehbaren Tisch suchen, ohne auf stilicheres Design verzichten zu wollen. Durch seitliches Ausziehen der Tischbeine und Einsetzen einer oder zwei Verlängerungen lässt sich die Tischplatte bei Bedarf im Handumdrehen vergrößern.

Fr Kime est une table caractérisée par la légèreté de ses formes, sa discrétion et son élégance. Particulièrement indiquée pour ceux qui recherchent le côté pratique d'une table à rallonges, sans pour autant renoncer au design. Le plateau est extensible grâce à la possibilité de faire coulisser littéralement les pieds et d'insérer une ou plusieurs rallonges.



Kime Bartoli Design
Tavolo. Table. Tisch. Table.

Pag. 238, 239, 240-241
Doluflex bianco / bianco
White Doluflex / white
Doluflex Weiss / Weiss
Doluflex blanc / blanc





Kime Bartoli Design
Tavolo. Table. Tisch. Table.

Pangea Dondoli e Pocci
Sedia. Chair. Stuhl. Chaise.

Kime Bartoli Design
Tavolo. Table. Tisch. Table.
Doluflex grigio antracite / grigio antracite
Anthracite grey Doluflex / anthracite grey
Doluflex Anthrazitgrau / Anthrazitgrau
Doluflex gris anthracite / gris antracite



Chat

Caratterizzato da una rigorosa linearità geometrica, Chat è un tavolo allungabile con una prolunga (Chat) o due (Chat Double). Il piano è in cristallo. Con lo spostamento laterale, le gambe si collocano alle estremità, senza intralciare le sedute; le prolunghe si aprono facilmente e automaticamente, aumentando la superficie d'appoggio.

En With a rigorous geometric linearity, Chat is an extending table with one extension (Chat) or two (Chat Double). The top is in glass. A side movement positions the legs at the end of the table, without getting in the way of the chairs. The extensions open easily and automatically, increasing the support surface.

De Der ausziehbare Tisch Chat überzeugt mit einer streng geometrischen Linienführung und ist mit einer (Chat) oder zwei (Chat Double) Verlängerungen erhältlich. Die Tischplatte besteht aus Glas. Wird die Tischplatte verlängert, rücken auch die Tischbeine entsprechend nach außen, so dass alle Gäste bequem sitzen können. Die Verlängerungen zur Vergrößerung der Auflagefläche öffnen sich automatisch.

Fr Caractérisée par des géométries rigoureusement linéaires, Chat est une table extensible avec une (Chat) ou deux rallonges (Chat Double). Le plateau est en cristal. Grâce au déplacement latéral, les pieds se placent aux extrémités, sans gêner les chaises; les rallonges s'ouvrent aisément, et automatiquement, augmentent la surface d'appui.

Chat Dondoli e Poggi
Tavolo. Table. Tisch. Table.

Marta
Sedia. Chair. Stuhl. Chaise.

Pag. 245, 246-247

Cristallo acidato bianco / bianco
White acid-treated glass / white
Geätztes Glas Weiss / Weiss
Cristal traité à l'acide blanc / blanc





Chat Double Dondoli e Poggi
Tavolo. Table. Tisch. Table.

Marta
Sedia. Chair. Stuhl. Chaise.



Chat Double Dondoli e Pucci
Tavolo. Table. Tisch. Table.
Blues Dondoli e Pucci
Sedia. Chair. Stuhl. Chaise.

Cristallo acidato nero / anodizzato nero
Black acid-treated glass / anodized black
Geätztes Glas Schwarz / Anodisiert Schwarz
Cristal traité à l'acide noir / anodisé noir





Chat Double Dondoli e Pocci
Tavolo. Table. Tisch. Table.

Marta
Sedia. Chair. Stuhl. Chaise.

Cristallo verniciato nero / anodizzato nero
Black painted glass / anodized black
Glas Schwarz lackiert / Anodisiert Schwarz
Cristal verni noir / anodisé noir



Fli

Leggerezza ed essenzialità sono i valori di riferimento del tavolo Fli, fisso o allungabile.

Ha le gambe in acciaio e il piano disponibile in cristallo oppure in Doluflex. Fli è dotato di prolunghe manuali indipendenti che permettono di aumentare la superficie d'appoggio a seconda delle esigenze.

En Lightness and elementary shapes are the reference values of the Fli table, fixed or extending. The legs are steel and the top is available in glass or Doluflex. Fli is equipped with independent manual extensions that increase the support surface according to requirements.

De Der Tisch Fli punktet mit optischer Leichtigkeit und schlichter Linienführung. Die Tischbeine bestehen aus Stahl, die wahlweise ausziehbar oder nicht ausziehbar. Die Tischplatte aus Glas oder Doluflex. Mithilfe der separaten manuellen Verlängerungen lässt sich die Auflagefläche von Fli jederzeit je nach Bedarf vergrößern.

Fr Légèreté et sobriété, telles sont les valeurs de référence de la table Fli, fixe ou extensible. Avec ses pieds en acier et son plateau en cristal ou Doluflex, Fli est équipée de rallonges manuelles indépendantes qui permettent d'augmenter la surface d'appui en fonction des besoins.

Fli
Tavolo. Table. Tisch. Table.
Blues Dondoli e Pucci
Sedia. Chair. Stuhl. Chaise.

Pag. 253, 254-255
Cristallo verniciato bianco / bianco
White painted glass / white
Glas Weiss lackiert / Weiss
Cristal verni blanc / blanc





Fli
Tavolo. Table. Tisch. Table.

Blues Dondoli e Poggi
Sedia. Chair. Stuhl. Chaise.



Fli
Tavolo. Table. Tisch. Table.
Doluflex bianco / bianco
White Doluflex / white
Doluflex Weiss / Weiss
Doluflex blanc / blanc

Informazioni tecniche. Technical information.
Technische Hinweise. Informations techniques.

Amond	P. 264	Octa	P. 278
AX	P. 260	Prora	P. 282
Big Table	P. 262	Sol	P. 284
Chat, Chat Double	P. 265	Still	P. 281
Flag	P. 266	TL	P. 286
Fli	P. 268	Tom	P. 288
Gap	P. 269	Tracks	P. 289
Greeny	P. 270	Twice	P. 290
Hulahoop	P. 271	Vanessa	P. 292
Kime	P. 272	Welded	P. 293
Mass Table	P. 273		
Match	P. 274		
Medley	P. 275		
Menù	P. 276		
Mille	P. 277		

AX FISSO / FIXED / FEST / FIXE



①

FINITURA PIANO / TOP FINISH / PLATTE AUSFÜHRUNG / FINITION PLAN

LACCATO

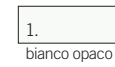

1. bianco opaco

IMPIALLACCIATO LEGNO

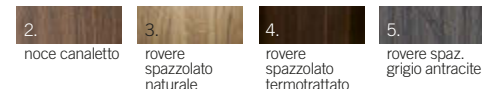

2. noce canaletto 3. rovere spazzolato naturale 4. rovere spazzolato termotrattato 5. rovere spaz. grigio antracite

LEGGNO MASSICCIO

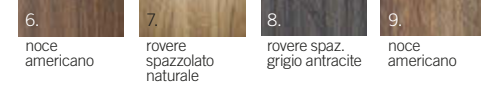

6. noce americano 7. rovere spazzolato naturale 8. rovere spaz. grigio antracite 9. noce americano

CRISTALLO

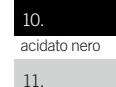

10. acidato nero 11. extrachiaro acidato bianco 12. acidato grigio antracite

CERAMICA LUCIDA



13. Calacatta 14. Paonazzetto 15. grigio grafite 16. bianco iridium

LACQUERED

1. mat white

VENEERED WOOD

2. walnut canaletto
3. natural polished oak
4. heat-treated polished oak
5. anthracite grey polished oak

SOLID WOOD

6. American walnut
7. natural polished oak
8. anthracite grey polished oak

WOOD WITH NATURAL EDGES

9. American walnut

GLASS

10. acid-treated black
11. extra-light acid treated white
12. acid-treated anthracite grey

GLOSSY CERAMIC

13. Calacatta
14. Paonazzetto

MATT CERAMIC

15. graphite grey
16. iridium white

LACKIERT

1. Weiss matt

HOLZ FURNIERT

2. Nussbaum Canaletto
3. Eiche Natur poliert
4. thermo-behandelte polierte Eiche
5. Eiche Anthrazitgrau poliert

MASSIVHOLZ

6. Amerikaner Nussbaum
7. Eiche Natur poliert
8. Eiche Anthrazitgrau poliert

HOLZ MIT WALDKANTE

9. Amerikaner Nussbaum

GLAS

10. Geätztes Schwarz
11. Geätztes extra-hell Weiss
12. Geätztes Anthrazitgrau

GLÄNZEND KERAMIC

13. Calacatta
14. Paonazzetto

MATT KERAMIC

15. Graphitgrau
16. Iridium Weiss

LAQUÉ

1. blanc opaque

BOIS PLAQUÉ

2. noyer canaletto
3. rouvre brossé naturel
4. rouvre brossé traité thermiquement
5. rouvre brossé gris anthracite

BOIS MASSIF

6. noyer américain
7. rouvre brossé naturel
8. rouvre brossé gris anthracite

BOIS AVEC CONTOUR NATUREL

9. noyer américain

CRISTAL

10. traité à l'acide noir
11. extra-clair traité à l'acide blanc
12. traité à l'acide gris anthracite

CÉRMIQUE BRILLANT

13. Calacatta
14. Paonazzetto

CÉRMIQUE OPAQUE

15. gris graphite
16. blanc iridium

②

FINITURA GAMBE / LEGS FINISH / BEINE AUSFÜHRUNG / FINITION PIEDS

VERNICIATO OPACO

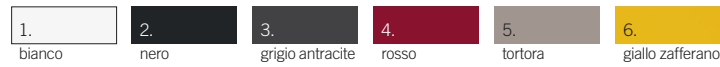

1. bianco 2. nero 3. grigio antracite 4. rosso 5. tortora 6. giallo zafferano

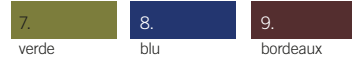

7. verde 8. blu 9. bordeaux

METALLO FINITURA



10. brunito

MAT PAINTED

1. white
2. black
3. anthracite grey
4. red
5. dove grey
6. saffron yellow
7. green
8. blue
9. bordeaux

LACKIERT MATT

1. Weiss
2. Schwarz
3. Anthrazitgrau
4. Rot
5. Taubengrau
6. Saafrangelb
7. Grün
8. Blau
9. Bordeaux

METALL AUSFÜHRUNG

10. Brüniert

VERNI OPAQUE

1. blanc
2. noir
3. gris anthracite
4. rouge
5. gris tourterelle
6. jaune safran
7. vert
8. bleu
9. bordeaux

FINITION MÉTAL

10. bruni

DIMENSIONI / DIMENSIONS / GRÖßEN / DIMENSIONS

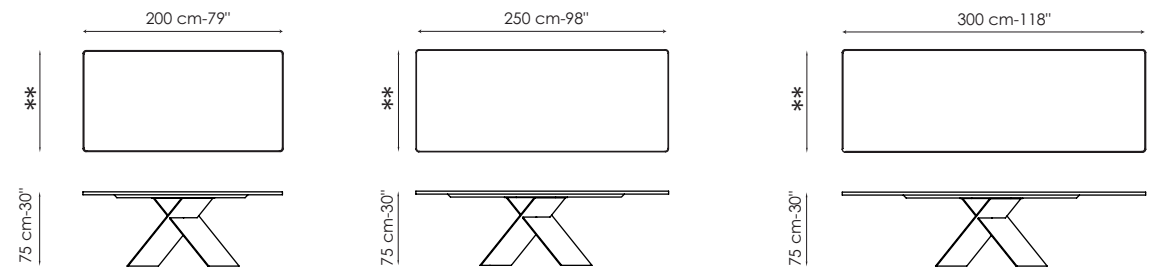
** 100 cm – 39.4"
legno, ceramica / wood, ceramic / Holz, Keramik / bois, céramique
99 cm – 39"
cristallo / glass / Glas / cristal** 100 cm – 39.4"
massiccio, impiallacciato, laccato, cristallo, ceramica / solid, veneered, lacquered, glass, ceramic / Massivholz, furniert, lackiert, Glas, Keramik / massif plaqué, laqué, cristal, céramique
110 cm – 43.3"
legno con bordi naturali / wood with natural edges / Holz mit Waldkante / bois avec contour naturel** 108 cm – 42.5"
massiccio, impiallacciato, laccato, cristallo, ceramica lucida / solid, veneered, lacquered, glass, glossy ceramic / Massivholz, furniert, lackiert, Glas, glänzend Keramik / massif plaqué, laqué, cristal, céramique brillante
100 cm – 39.4"
ceramica opaca / matt ceramic / céramique opaque
120 cm – 47.2"
legno con bordi naturali / wood with natural edges / Holz mit Waldkante / bois avec contour naturel

AX ALLUNGABILE / EXTENDABLE / AUSZIEHBAR / EXTENSIBLE



①

FINITURA PIANO E PROLUNGHE / TOP AND EXTENSIONS FINISH / PLATTE UND VERLÄNGERUNGEN AUSFÜHRUNG / FINITION PLAN ET RALLONGES

LACCATO OPACO

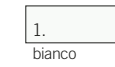

1. bianco

IMPIALLACCIATO LEGNO solo per 200 cm

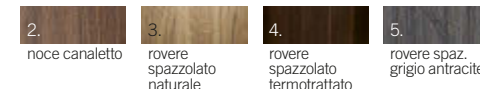

2. noce canaletto 3. rovere spazzolato naturale 4. rovere spazzolato termotrattato 5. rovere spaz. grigio antracite

CRISTALLO

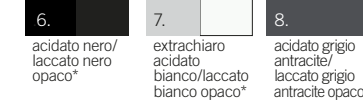

6. acidato nero/laccato nero opaco* 7. extrachiaro acidato bianco/laccato bianco opaco* 8. acidato grigio antracite/laccato grigio antracite opaco*

CERAMICA OPAÇA solo per 200 cm



9. bianco iridium 10. grigio grafite

CERAMICA LUCIDA solo per 200 cm



11. Calacatta 12. Paonazzetto

LACQUERED

1. mat white

VENEERED WOOD only for 200 cm

2. walnut canaletto
3. natural polished oak
4. heat-treated polished oak
5. anthracite grey polished oak

GLASS

6. acid-treated black/lacquered mat black*
7. extra-light acid treated white/lacquered mat white*
8. acid-treated anthracite grey/lacquered mat anthracite grey*

MATT CERAMIC only for 200 cm

9. white iridium
10. graphite grey

GLOSSY CERAMIC only for 200 cm

11. Calacatta
12. Paonazzetto

LACKIERT

1. Weiss matt

HOLZ FURNIERT nur für 200 cm

2. Nussbaum Canaletto
3. Eiche Natur poliert
4. thermo-behandelte polierte Eiche
5. Eiche Anthrazitgrau poliert

GLAS

6. Geätztes Schwarz/Lackiert Schwarz matt*
7. Geätztes extra-hell Weiss/Lackiert Weiss matt*
8. Geätztes Anthrazitgrau/Lackiert Anthrazitgrau matt*

MATT KERAMIC nur für 200 cm

9. Weiss Iridium
10. Graphitgrau

GLÄNZEND KERAMIC nur für 200 cm

11. Calacatta
12. Paonazzetto

LAQUÉ

1. blanc opaque

BOIS PLAQUÉ seulement 200 cm

2. noyer canaletto
3. rouvre brossé naturel
4. rouvre brossé traité thermiquement
5. rouvre brossé gris anthracite

CRISTAL

6. traité à l'acide noir/laqué noir opaque*
7. extra-clair traité à l'acide blanc/laqué blanc opaque*
8. traité à l'acide gris anthracite/laqué gris anthracite opaque*

CÉRMIQUE OPAQUE seulement 200 cm

9. blanc iridium
10. gris graphite

CÉRMIQUE BRILLANT seulement 200 cm

11. Calacatta
12. Paonazzetto

②

FINITURA GAMBE / LEGS FINISH / BEINE AUSFÜHRUNG / FINITION PIEDS

VERNICIATO OPACO

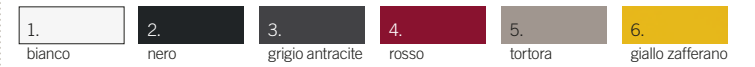

1. bianco 2. nero 3. grigio antracite 4. rosso 5. tortora 6. giallo zafferano



7. verde 8. blu 9. bordeaux

METALLO FINITURA



10. brunito

MAT PAINTED

1. white
2. black
3. anthracite grey
4. red
5. dove grey
6. saffron yellow
7. green
8. blue
9. bordeaux

LACKIERT MATT

1. Weiss
2. Schwarz
3. Anthrazitgrau
4. Rot
5. Taubengrau
6. Saafrangelb
7. Grün
8. Blau
9. Bordeaux

METALL AUSFÜHRUNG

10. Brüniert

VERNI OPAQUE

1. blanc
2. noir
3. gris anthracite
4. rouge
5. gris tourterelle
6. jaune safran
7. vert
8. bleu
9. bordeaux

FINITION MÉTAL

10. bruni

DIMENSIONI / DIMENSIONS / GRÖßEN / DIMENSIONS

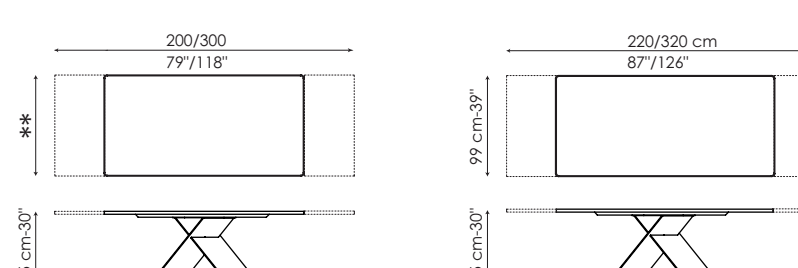
** 99 cm – 39"
legno, cristallo / wood, glass / Holz, Glas / bois, cristal
100 cm – 39.4"
ceramica / ceramic / Keramik / céramique* prolunga disponibile anche in cristallo
* extension also available in glass
* Verlängerung verfügbar auch auf Glas
* rallonge disponible aussi en cristal

BIG TABLE FISSO / FIXED / FEST / FIXE



1
FINITURA PIANO / TOP FINISH / PLATTE AUSFÜHRUNG / FINITION PLAN

- LACCATO OPACO**
1. bianco opaco
- LEGGNO MASSELLO**
2. noce americano
3. noce 400
4. rovere spazzolato naturale
5. rovere spazz. grigio antracite
- LEGGNO CON BORDI NATURALI**
6. noce canaletto
7. rovere spazz. termotrattato
8. noce americano
- CRISTALLO**
9. acidato nero
10. extrachiaro acidato bianco
11. acidato grigio antracite
- CERAMICA OPACA**
12. bianco iridium
13. grigio grafite
- CERAMICA LUCIDA**
14. Calacatta
15. Paonazzetto

- MAT LACQUERED**
1. white
- SOLID WOOD**
2. American walnut
3. walnut 400
4. natural polished oak
5. anthracite grey polished oak
- VENEERED WOOD**
6. walnut canaletto
7. heat-treated polished oak
- WOOD WITH NATURAL EDGES**
8. American walnut
- GLASS**
9. acid-treated black
10. extra-light acid treated white
11. acid-treated anthracite grey
- MAT CERAMIC**
12. white iridium
13. graphite grey
- GLOSSY CERAMIC**
14. Calacatta
15. Paonazzetto
- MATT LACKIERT**
1. Weiss
- MASSIVHOLZ**
2. Amerikaner Nussbaum
3. Nussbaum 400
4. Eiche Natur poliert
5. Eiche Anthrazitgrau poliert
- HOLZ FURNIERT**
6. Nussbaum Canaletto
7. thermo-behandelte polierte Eiche
- HOLZ MIT WALDKANTE**
8. Amerikaner Nussbaum
- GLAS**
9. Geätztes Schwarz
10. Geätztes extra-hell Weiss
11. Geätztes Anthrazitgrau
- MATT KERAMIC**
12. Weiss Iridium
13. Graphitgrau
- GLÄNZEND KERAMIC**
14. Calacatta
15. Paonazzetto
- LAQUÉ OPAQUE**
1. opaque
- BOIS MASSIF**
2. noyer américain
3. noyer 400
4. rovere brossé naturel
5. rovere brossé gris anthracite
- BOIS PLAQUÉ**
6. noyer canaletto
7. rovere brossé traité thermiquement
- BOIS AVEC CONTOUR NATUREL**
8. noyer américain
- CRISTAL**
9. traité à l'acide noir
10. extra-clair traité à l'acide blanc
11. traité à l'acide gris anthracite
- CÉRAMIQUE OPAQUE**
12. blanc iridium
13. gris graphite
- CÉRAMIQUE BRILLANT**
14. Calacatta
15. Paonazzetto

DIMENSIONI / DIMENSIONS / GRÖßEN / DIMENSIONS

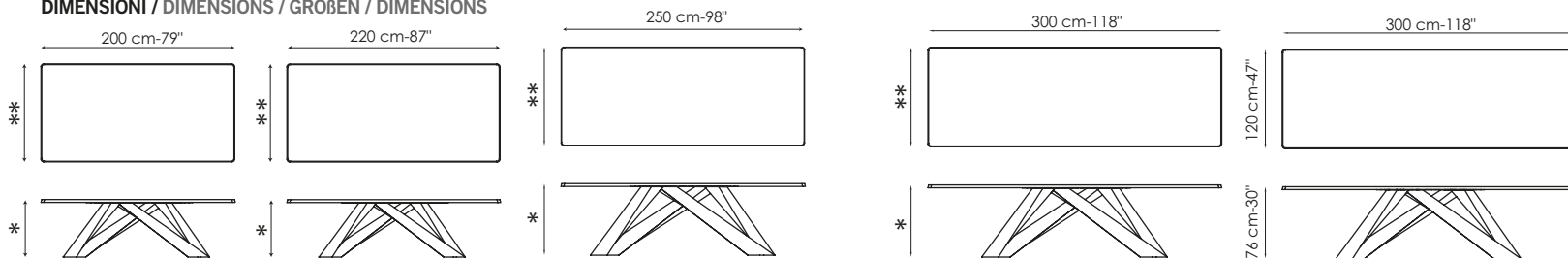

- ** 100 cm – 39.4" legno, ceramica / wood, ceramic / Holz, Keramik / bois, céramique
99 cm – 39" cristallo / glass / Glas / cristal
- * 74,50 cm – 29.3" laccato, impiallacciato / lacquered, veneered / lackiert, furniert / laqué, plaqué
76 cm – 29.9" massello, legno con bordi naturali / solid, wood with natural edges / Massivholz, Holz mit Waldkante / massif, bois avec contour naturel
74 cm – 29.2" cristallo, ceramica / glass, ceramic / Glas, Keramik / cristal, céramique
- ** 100 cm – 39.4" massello, impiallacciato, laccato, cristallo, ceramica / solid, veneered, lacquered, glass, ceramic / Massivholz, furniert, lackiert, Glas, Keramik / massif, plaqué, laqué, cristal, céramique
110 cm – 43.3" legno con bordi naturali / wood with natural edges / Holz mit Waldkante / bois avec contour naturel
- * 74,50 cm – 29.3" laccato, impiallacciato / lacquered, veneered / lackiert, furniert / laqué, plaqué
76 cm – 29.9" massello, legno con bordi naturali / solid, wood with natural edges / Massivholz, Holz mit Waldkante / massif, bois avec contour naturel
74 cm – 29.2" cristallo, ceramica / glass, ceramic / Glas, Keramik / cristal, céramique
- ** 108 cm – 42.5" massello, impiallacciato, laccato, cristallo, ceramica lucida / solid, veneered, lacquered, glass, glossy ceramic / Massivholz, furniert, lackiert, Glas, glänzend Keramik / massif, plaqué, laqué, cristal, céramique brillante
- 100 cm – 39.4" ceramica opaca / mat ceramic / matt Keramik / céramique opaque
- * 74,50 cm – 29.3" laccato, impiallacciato / lacquered, veneered / lackiert, furniert / laqué, plaqué
76 cm – 29.9" massello, legno con bordi naturali / solid, wood with natural edges / Massivholz, Holz mit Waldkante / massif, bois avec contour naturel
74 cm – 29.2" cristallo, ceramica / glass, ceramic / Glas, Keramik / cristal, céramique
- 300x120 cm – 118x47" massello, legno con bordi naturali / solid wood, wood with natural edges / Massivholz, Holz mit Waldkante / bois massif, bois avec contour naturel

BIG TABLE ALLUNGABILE / EXTENDABLE / AUSZIEHBAR / EXTENSIBLE



1
FINITURA PIANO E PROLUNGHE / TOP AND EXTENSIONS FINISH / PLATTE UND VERLÄNGERUNGEN AUSFÜHRUNG / FINITION PLAN ET RALLONGES

- LACCATO**
1. bianco opaco
- IMPIALLACCIATO LEGNO solo per 200 cm.**
2. noce canaletto
3. rovere spazz. termotrattato
- CRISTALLO**
4. acidato nero/laccato nero opaco*
5. extrachiaro acidato bianco/laccato bianco opaco*
6. acidato grigio antracite/laccato grigio antracite opaco*
- CERAMICA OPACA solo per 200 cm.**
7. bianco iridium
8. grigio grafite
- CERAMICA LUCIDA solo per 200 cm.**
9. Calacatta
10. Paonazzetto

- MAT LACQUERED**
1. white
- VENEERED WOOD only for 200 cm.**
2. walnut canaletto
3. heat-treated polished oak
- GLASS**
4. acid-treated black/lacquered mat black*
5. extra-light acid treated white/lacquered mat white*
6. acid-treated anthracite grey/lacquered mat anthracite grey*
- MAT CERAMIC only for 200 cm.**
7. white iridium
8. graphite grey
- GLOSSY CERAMIC only for 200 cm.**
9. Calacatta
10. Paonazzetto
- MATT LACKIERT**
1. Weiss
- HOLZ FURNIERT nur für 200 cm.**
2. Nussbaum Canaletto
3. thermo-behandelte polierte Eiche
- GLAS**
4. Geätztes Schwarz/Lackiert Schwarz matt*
5. Geätztes extra-hell Weiss/Lackiert Weiss matt*
6. Geätztes Anthrazitgrau/Lackiert Anthrazitgrau matt*
- MATT KERAMIC nur für 200 cm.**
7. Weiss Iridium
8. Graphitgrau
- GLÄNZEND KERAMIC nur für 200 cm.**
9. Calacatta
10. Paonazzetto
- LAQUÉ OPAQUE**
1. blanc
- BOIS PLAQUÉ seulement 200 cm.**
2. noyer canaletto
3. rovere brossé traité thermiquement
- CRISTAL**
4. traité à l'acide noir/laqué noir opaque*
5. extra-clair traité à l'acide blanc/laqué blanc opaque*
6. traité à l'acide gris anthracite/laqué gris anthracite opaque*
- CÉRAMIQUE OPAQUE seulement 200 cm.**
7. blanc iridium
8. gris graphite
- CÉRAMIQUE BRILLANT seulement 200 cm.**
9. Calacatta
10. Paonazzetto

DIMENSIONI / DIMENSIONS / GRÖßEN / DIMENSIONS

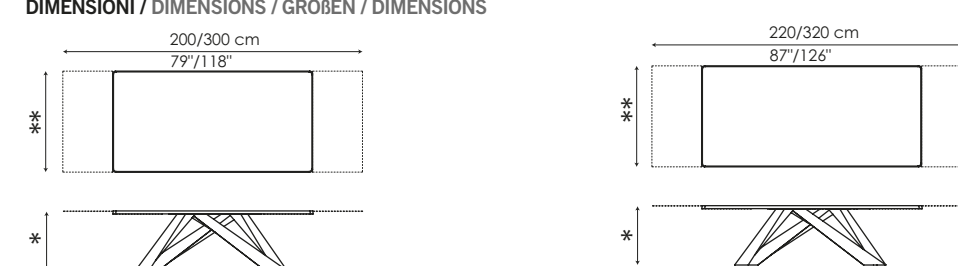

- ** 100 cm – 39.4" legno, ceramica / wood, ceramic / Holz, Keramik / bois, céramique
99 cm – 39" cristallo / glass / Glas / cristal
- * 75 cm – 29.5" legno / wood / Holz / bois
74,50 cm – 29.3" cristallo / glass / Glas / cristal
- ** 100 cm – 39.4" legno / wood / Holz / bois
99 cm – 39" cristallo / glass / Glas / cristal
- * 75 cm – 29.5" legno / wood / Holz / bois
74,50 cm – 29.3" cristallo / glass / Glas / cristal

* prolunga disponibile anche in cristallo
* extension also available in glass
* Verlängerung verfügbar auch auf Glas
* rallonge disponible aussi en cristal

AMOND



① FINITURA PIANO / TOP FINISH / PLATTE AUSFÜHRUNG / FINITION PLAN

LEGGNO IMPIALLACCIATO



LEGGNO CON BORDI NATURALI

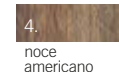

CRISTALLO

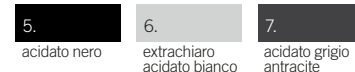

CERAMICA LUCIDA



CERAMICA OPACA

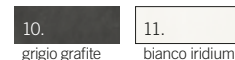

VENEREED WOOD

- walnut canaletto (not polished)
- natural polished oak
- anthracite grey polished oak

HOLZ FURNIERT

- Nussbaum Canaletto (nicht poliert)
- Eiche Natur poliert
- Eiche Anthrazitgrau poliert

BOIS PLAQUÉ

- noyer canaletto (pas brossé)
- rouvre brossé naturel
- rouvre brossé gris anthracite

WOOD WITH NATURAL EDGES

- American walnut

HOLZ MIT WALDKANTE

- Amerikaner Nussbaum

BOIS AVEC CONTOUR NATUREL

- noyer américain

GLASS

- acid-treated black
- extra-light acid treated white
- acid-treated anthracite grey

GLAS

- Geätztes Schwarz
- Geätztes extra-hell Weiss
- Geätztes Anthrazitgrau

CRISTAL

- traité à l'acide noir
- extra-clair traité à l'acide blanc
- traité à l'acide gris anthracite

GLOSSY CERAMIC

- Calacatta
- Paonazzetto

GLÄNZEND CERAMIC

- Calacatta
- Paonazzetto

CÉRAMIQUE BRILLANT

- Calacatta
- Paonazzetto

MAT CERAMIC

- graphite grey
- iridium white

MATT CERAMIC

- Graphitgrau
- Iridium Weiss

CÉRAMIQUE OPAQUE

- gris graphite
- blanc iridium

DIMENSIONI / DIMENSIONS / GRÖßEN / DIMENSIONS

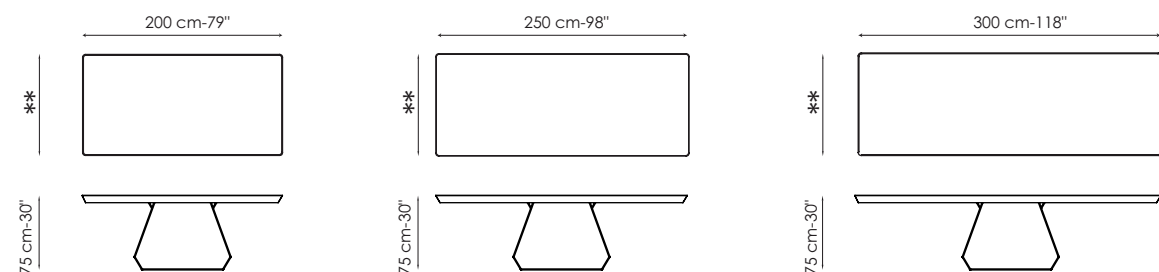

** 100 cm – 39.4"
legno, ceramica / wood, ceramic / Holz, Keramik / Bois, céramique
99 cm – 39"
cristallo / glass / glas / cristal

** 108 cm – 42.5"
impiallacciato / veneered / furniert / plaqué
100 cm – 39.4"
cristallo, ceramica / glass, ceramic / Glas, Keramik / cristal, céramique
110 cm – 43.3"
legno con bordi naturali / wood with natural edges / Holz mit Waldkante / bois avec contour naturel

** 108 cm – 42.5"
impiallacciato, cristallo, ceramica lucida / veneered, glass, glossy ceramic / furniert, Glas, glänzend Keramik / plaqué, cristal, céramique brillante
100 cm – 39.4"
ceramica opaca / mat ceramic / matt Keramik / céramique opaque
120 cm – 47.2"
legno con bordi naturali / wood with natural edges / Holz mit Waldkante / bois avec contour naturel

CHAT, CHAT DOUBLE

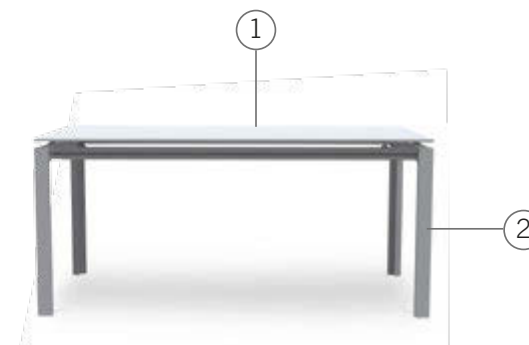

① FINITURA PIANO / TOP FINISH / PLATTE AUSFÜHRUNG / FINITION PLAN

CRISTALLO



GLASS

- black painted
- extra-light glass painted white
- acid-treated black glass
- extra-light glass acid-treated white

GLAS

- Schwarz lackiert
- Glas extra-hell Weiss lackiert
- Geätztes Glas Schwarz
- Geätztes Glas extra-hell Weiss

CRISTAL

- verni noir
- cristal extra-clair verni blanc
- cristal traité à l'acide noir
- cristal extra-clair traité à l'acide blanc

② FINITURA GAMBE / LEGS FINISH / BEINE AUSFÜHRUNG / FINITION PIEDS

ALLUMINIO



ALUMINIUM

- anodized silver
- anodized black
- painted mat white
- painted mat anthracite grey

ALUMINIUM

- Anodisiert Silber
- Anodisiert Schwarz
- Lackiert Weiss matt
- Lackiert Anthrazitgrau matt

ALUMINIUM

- anodisé argent
- anodisé noir
- verni blanc opaque
- verni gris anthracite opaque

DIMENSIONI / DIMENSIONS / GRÖßEN / DIMENSIONS

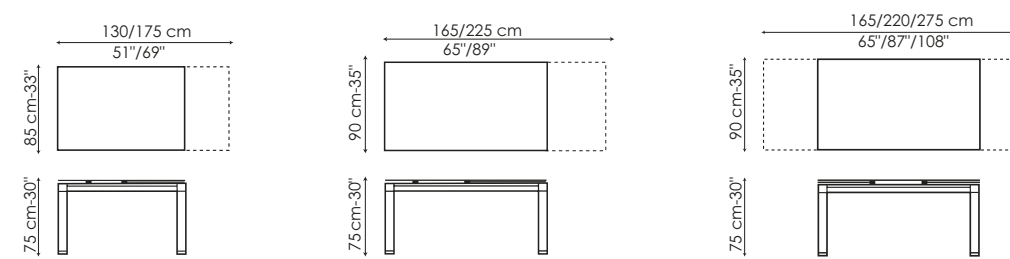

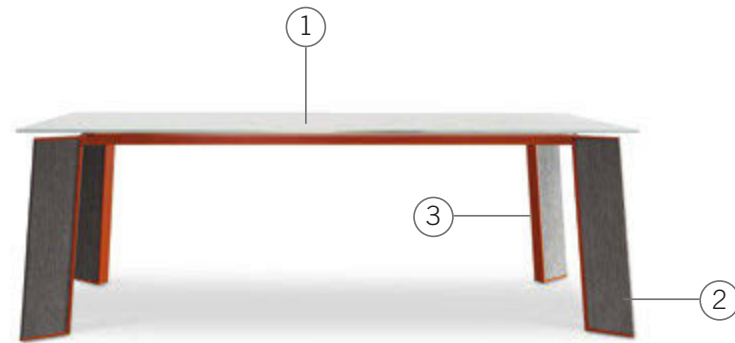
FLAG FISSO / FIXED / FEST / FIXE

①

FINITURA PIANO / TOP FINISH / PLATTE AUSFÜHRUNG / FINITION PLAN**CRISTALLO**

- | | | |
|-------------------------------|-----------------|-------------------------------|
| 1. extrachiaro vernic. bianco | 2. acidato nero | 3. extrachiaro acidato bianco |
|-------------------------------|-----------------|-------------------------------|

PIETRA

- | |
|---------------------|
| 4. pietra basaltina |
|---------------------|

GLASS

- extra-light glass painted white
- acid treated black glass
- extra-light glass acid treated white

GLAS

- extra-hell Weiss lackiert
- Geätztes glas Schwarz
- Geätztes glas extra-hell Weiss

CRISTAL

- cristal extra-clair verni blanc
- cristal traité à l'acide noir
- cristal extra-clair traité à l'acide blanc

STONE

- stone basaltina

STEIN

- Stein Basaltina

PIERRE

- Pierre basaltina

②

FINITURA GAMBE / LEGS FINISH / BEINE AUSFÜHRUNG / FINITION PIEDS**IMPIALLACCIATO LEGNO**

- | | | |
|-------------------------------|-------------------------------|-------------------|
| 1. frassino spazzolato bianco | 2. frassino spazzolato grigio | 3. noce canaletto |
|-------------------------------|-------------------------------|-------------------|

VENEERED WOOD

- ash polished white
- ash polished grey
- walnut canaletto

HOLZ FURNIERT

- Eschen Weiss poliert
- Eschen Grau poliert
- Nussbaum Caneletto

BOIS PLAQUÉ

- frêne blanc brossé
- frêne griss brossé
- noyer canaletto

③

PROFILO GAMBE / EDGE FINISH / BEINE PROFIL / BORDURE DES PIEDS**VERNICIATO OPACO**

- | | | | |
|------------|---------------------|------------|-----------|
| 1. tortora | 2. grigio antracite | 3. arancio | 4. bianco |
|------------|---------------------|------------|-----------|

PAINTED MAT

- dove grey
- anthracite grey
- orange
- white

LACKIERT MATT

- Taubengrau
- Anthrazitgrau
- Orange
- Weiss

VERNI OPAQUE

- gris tourterelle
- gris anthracite
- orange
- blanc

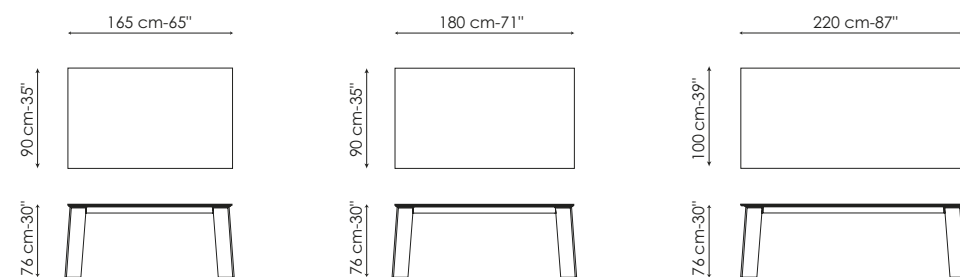
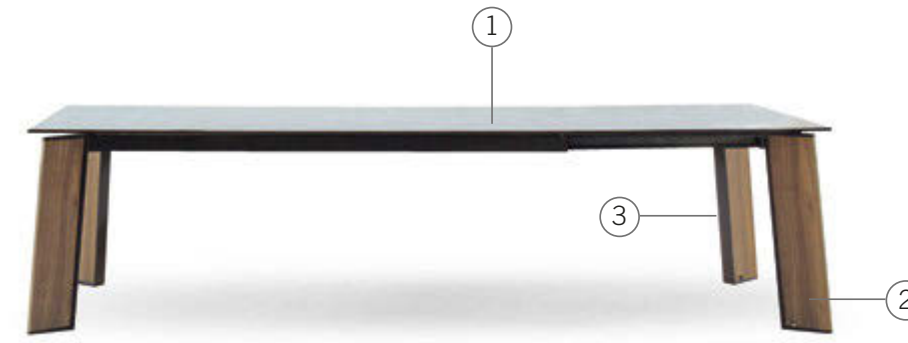
DIMENSIONI / DIMENSIONS / GRÖßEN / DIMENSIONS**FLAG ALLUNGABILE / EXTENDABLE / AUSZIEHBAR / EXTENSIBLE**

①

FINITURA PIANO E PROLUNGHE / TOP AND EXTENSIONS FINISH / PLATTE UND VERLÄNGERUNGEN AUSFÜHRUNG / FINITION PLAN ET RALLONGES**CRISTALLO**

- | | | |
|---|---|---|
| 1. cristallo extrachiaro vernic. bianco/lacato bianco opaco | 2. cristallo acidato nero/lacato nero opaco | 3. cristallo extrachiaro acidato bianco/lacato bianco opaco |
|---|---|---|

PIETRA

- | |
|---------------------------------------|
| 4. pietra basaltina/lacato nero opaco |
|---------------------------------------|

GLASS

- extra-light glass painted white/lacquered mat white
- acid-treated black glass/lacquered mat black
- extra-light glass acid-treated white/lacquered mat white

GLAS

- Glas extra-hell Weiss lackiert/Lackiert Weiss matt
- Geätztes Glas Schwarz/Lackiert Schwarz matt
- Geätztes Glas extra-hell Weiss/Lackiert Weiss matt

CRISTAL

- cristal extra-clair verni blanc-laqué blanc opaque
- cristal traité à l'acide noir/laqué noir opaque
- cristal extra-clair traité à l'acide blanc/laqué blanc opaque

STONE

- stone basaltina/lacquered mat black

STEIN

- Stein Basaltina/Lackiert Schwarz matt

PIERRE

- pierre basaltina/laqué noir opaque

③

PROFILO GAMBE / EDGE FINISH / BEINE PROFIL / FINITION PIEDS**VERNICIATO**

- | | | | |
|------------|---------------------|------------|-----------|
| 1. tortora | 2. grigio antracite | 3. arancio | 4. bianco |
|------------|---------------------|------------|-----------|

PAINTED MAT

- dove grey
- anthracite grey
- orange
- white

LACKIERT MATT

- Taubengrau
- Anthrazitgrau
- Orange
- Weiss

VERNI OPAQUE

- gris tourterelle
- gris anthracite
- orange
- blanc

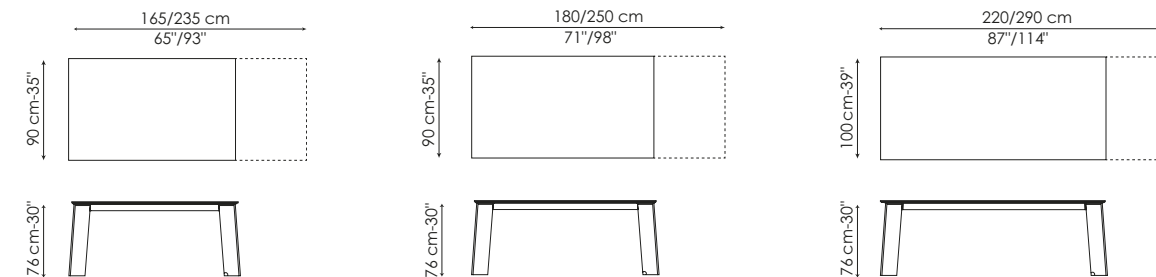
DIMENSIONI / DIMENSIONS / GRÖßEN / DIMENSIONS

FLI

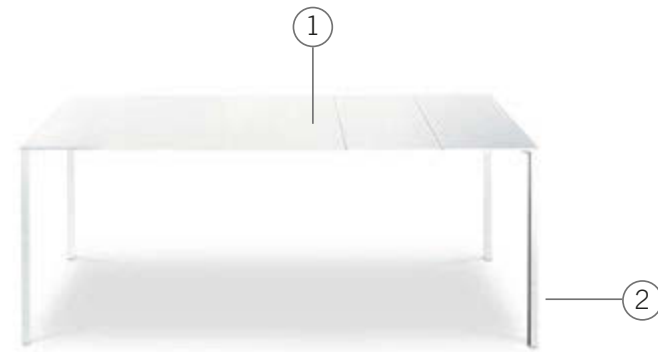

①

FINITURA PIANO E PROLUNGHE / TOP AND EXTENSIONS FINISH / PLATTE UND VERLÄNGERUNGEN AUSFÜHRUNG / FINITION PLAN ET RALLONGES**CRISTALLO**

1.

cristallo extrachiaro vernic. bianco/
Doluflex® laminato bianco**DOLUFLEX®**

2.

laminato bianco

GLASS1. extra-light glass painted
white/Doluflex® white
laminated**GLAS**1. Glas extra-hell Weiss
lackiert/Doluflex® Laminat
Weiss**CRISTAL**1. cristal extra-clair verni
blanc/Doluflex® laminé
blanc**DOLUFLEX®**

2. laminated white

DOLUFLEX®

2. Laminat Weiss

DOLUFLEX®

2. laminé blanc

②

FINITURA GAMBE / LEGS FINISH / BEINE AUSFÜHRUNG / FINITION PIEDS**VERNICIATO**

1.

verniciato
bianco lucido

2.

verniciato
argento opaco

3.

verniciato
grigio antracite
opaco**METALLO**

4.

cromato

PAINTED1. painted glossy white
2. painted mat silver
3. painted mat anthracite grey**LACKIERT**1. Lackiert Weiss glänzend
2. Lackiert Silber matt
3. Lackiert Anthrazitgrau
matt**VERNI**1. verni blanc brillant
2. verni argent opaque
3. verni gris anthracite opaque**METAL**

4. chrome-plated

METALL

4. Verchromt

MÉTAL

4. chromé

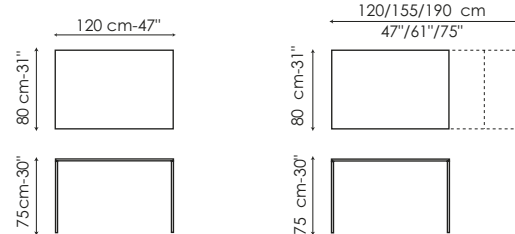
DIMENSIONI / DIMENSIONS / GRÖßEN / DIMENSIONS

GAP



①

FINITURA PIANO / TOP FINISH / PLATTE AUSFÜHRUNG / FINITION PLAN**LACCATO**

1.

bianco opaco

IMPIALLACCIATO LEGNO

2.

noce canaletto

3.

rovere
spazzolato
naturale

4.

rovere
spazzolato
termotrattato

5.

rovere
spazzolato
grigio antracite**LEGNO MASSICCIO**

6.

rovere
spazzolato
naturale

7.

rovere
spazzolato
grigio antracite

8.

noce
americano**LEGNO CON BORDI NATURALI**

9.

noce
americano**CRISTALLO**

10.

acidato nero

11.

extrachiaro
acidato bianco

12.

acidato grigio
antracite**MARMO**

13.

Carrara
bianco opaco**CERAMICA OPACA**

14.

bianco iridium

15.

grigio grafite

CERAMICA LUCIDA

16.

Calacatta

17.

Paonazzetto

LACQUERED

1. mat white

VENEERED WOOD2. walnut canaletto
3. natural polished oak
4. heat-treated polished oak
5. anthracite grey polished oak**SOLID WOOD**6. natural polished oak
7. anthracite grey polished oak
8. American walnut**WOOD WITH NATURAL EDGES**

9. American walnut

GLASS10. acid-treated black
11. extra-light acid treated white
12. acid-treated anthracite grey**MARBLE**

13. mat white Carrara

MAT CERAMIC14. graphite grey
15. iridium white**GLOSSY CERAMIC**16. Calacatta
17. Paonazzetto**LACKIERT**

1. Weiss matt

HOLZ FURNIERT2. Nussbaum Canaletto
3. Eiche Natur poliert
4. thermo-behandelte
polierte Eiche
5. Eiche Anthrazitgrau poliert**MASSIVHOLZ**6. Eiche Natur poliert
7. Eiche Anthrazitgrau poliert
8. Amerikaner Nussbaum**HOLZ MIT WALDKANTE**

9. Amerikaner Nussbaum

GLAS10. Geätztes Schwarz
11. Geätztes extra-hell Weiss
12. Geätztes Anthrazitgrau**MARMOR**

13. Weiss matt Carrara

MATT KERAMIC14. Graphitgrau
15. Iridium Weiss**GLÄNZEND KERAMIC**16. Calacatta
17. Paonazzetto**LAQUÉ**

1. blanc opaque

BOIS PLAQUÉ2. noyer canaletto
3. rouvre brossé naturel
4. rouvre brossé traité thermiquement
5. rouvre brossé gris anthracite**BOIS MASSIF**6. rouvre brossé naturel
7. rouvre brossé gris anthracite
8. noyer américain**BOIS AVEC CONTOUR NATUREL**

9. noyer américain

CRISTAL10. traité à l'acide noir
11. extra-clair traité à l'acide blanc
12. traité à l'acide gris anthracite**MARBRE**

13. blanc opaque Carrara

CÉRAMIQUE OPAQUE14. gris graphite
15. blanc iridium**CÉRAMIQUE BRILLANT**16. Calacatta
17. Paonazzetto

②

FINITURA GAMBE / LEGS FINISH / BEINE AUSFÜHRUNG / FINITION PIEDS**VERNICIATO OPACO**

1.

bianco

2.

grigio antracite

3.

verde

4.

rosso

5.

marrone

METALLO

6.

acciaio corten

MAT PAINTED1. white
2. anthracite grey
3. green
4. red
5. brown**METAL**

6. Corten steel

LACKIERT MATT1. Weiss
2. Anthrazitgrau
3. Grün
4. Rot
5. Braun**METALL**

6. Corten Stahl

VERNI OPAQUE1. blanc
2. gris anthracite
3. vert
4. rouge
5. marron**METAL**

6. acier corten

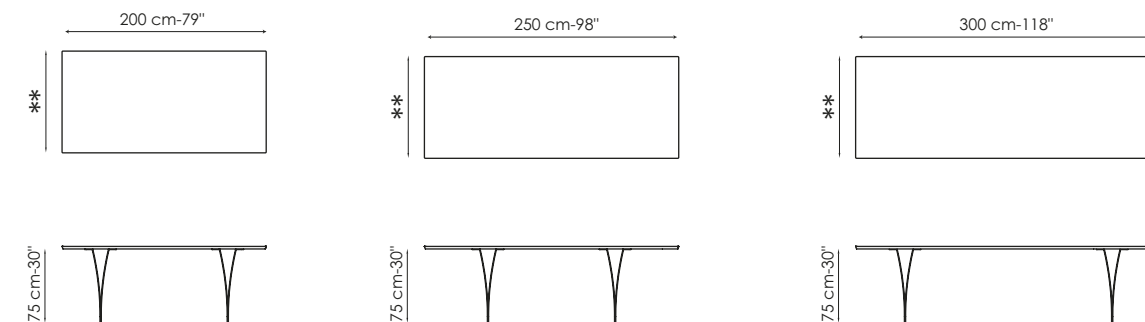
DIMENSIONI / DIMENSIONS / GRÖßEN / DIMENSIONS** 100 cm - 39.4"
legno, ceramica, marmo / wood, ceramic, marble /
Holz, Keramik, Marmor / bois, céramique, marbre
99 cm - 39"
cristallo / glass / glas / cristal** 100 cm - 39.4"
massiccio, impiallacciato, laccato, cristallo, ceramica,
marmo / solid, veneered, lacquered, glass, ceramic, marble /
Massivholz, furniert, lackiert, Glas, Keramik, Marmor / massif,
plaque, laqué, cristal, céramique, marbre
110 cm - 43.3"
legno con bordi naturali / wood with natural edges / Holz mit
Waldkante / bois avec contour naturel** 108 cm - 42.5"
massiccio, impiallacciato, laccato, cristallo, ceramica lucida / solid, veneered,
lacquered, glass, glossy ceramic / Massivholz, furniert, lackiert, Glas, glänzend Keramik
/ massif, plaque, laqué, cristal, céramique brillante
100 cm - 39.4"
ceramica opaca / mat ceramic / matt Keramik / céramique opaque
120 cm - 47.2"
legno con bordi naturali / wood with natural edges / Holz mit Waldkante / bois avec
contour naturel

GREENY



① FINITURA PIANO / TOP FINISH / PLATTE AUSFÜHRUNG / FINITION PLAN

CRISTALLO

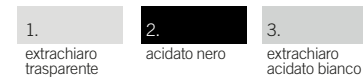

MARMO LUCIDO O OPACO

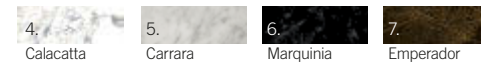

CERAMICA LUCIDA (solo Ø120 cm, Ø140 cm)



GLASS

- extra-light transparent
- acid-treated black
- extra light acid-treated white

GLOSSY OR MATT MARBLE

- Calacatta
- Carrara
- Marquinia
- Emperador

GLOSSY CERAMIC only Ø120 cm, Ø140 cm

- Calacatta
- Paonazzetto

GLAS

- Klarglass extra-hell
- Geätztes Schwarz
- Geätztes extra-hell Weiss

GLÄNZEND ODER MATT MARMOR

- Calacatta
- Carrara
- Marquinia
- Emperador

GLÄNZEND KERAMIC nur für Ø120 cm, Ø140 cm

- Calacatta
- Paonazzetto

CRISTAL

- transparent extra-clair
- traité à l'acide noir
- extra-clair traité à l'acide blanc

MARBRE BRILLANT OU OPAQUE

- Calacatta
- Carrara
- Marquinia
- Emperador

CÉRAMIQUE BRILLANT seulement Ø120 cm, Ø140 cm

- Calacatta
- Paonazzetto

② FINITURA BASE / BASE FINISH / BASIS AUSFÜHRUNG / FINITION BASE

LEGNO MASSELLO



SOLID WOOD

- American walnut (no polished)
- ash grey
- ash natural

MASSIVHOLZ

- Amerikaner Nussbaum (nicht poliert)
- Esche Grau
- Esche Natur

BOIS MASSIF

- noyer américain (pas brossé)
- frêne gris
- frêne naturel

DIMENSIONI / DIMENSIONS / GRÖßEN / DIMENSIONS

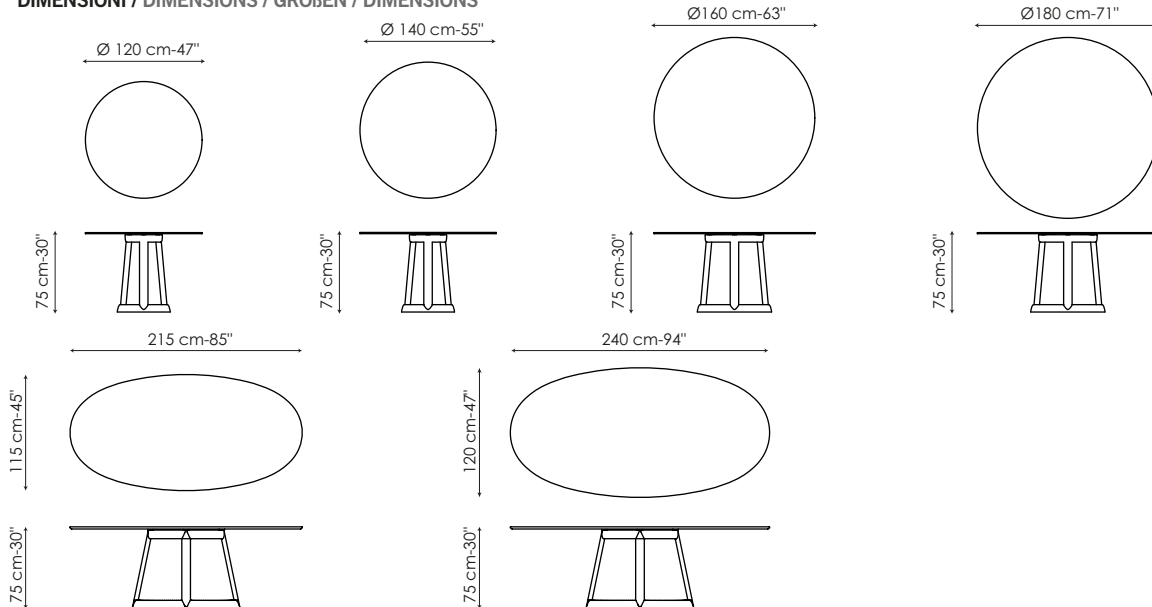

HULAHOOP

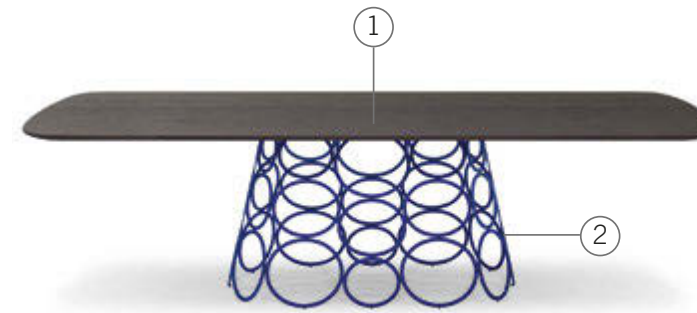

① FINITURA PIANO / TOP FINISH / PLATTE AUSFÜHRUNG / FINITION PLAN

LACCATO OPACO (solo 220, 280 cm)

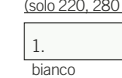

LEGNO MASSELLO



CERAMICA LUCIDA (no Ø160 cm, Ø180 cm)



CRISTALLO

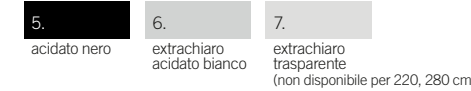

MARMO LUCIDO O OPACO



MAT LACQUERED only 220, 280 cm

- white

SOLID WOOD

- american walnut
- natural polished oak
- anthracite grey polished oak

GLASS

- acid-treated black
- extra light acid-treated white
- extra-light transparent (not available for 220, 280 cm)

GLOSSY CERAMIC not Ø160 cm, Ø180 cm

- Calacatta
- Paonazzetto

GLOSSY OR MATT MARBLE

- Calacatta
- Carrara
- Marquinia
- Emperador

MATT LACKIERT nur für 220, 280 cm

- Weiss

MASSIVHOLZ

- Amerikaner Nussbaum
- Eiche Natur poliert
- Eiche Anthrazitgrau poliert

GLAS

- Geätztes Schwarz
- Geätztes extra-hell Weiss
- Klarglass extra-hell (nicht verfügbar für 220, 280 cm)

GLÄNZEND KERAMIC nicht Ø160 cm, Ø180 cm

- Calacatta
- Paonazzetto

GLÄNZEND ODER MATT MARMOR

- Calacatta
- Carrara
- Marquinia
- Emperador

LAQUÉ OPAQUE seulement 220, 280 cm

- blanc

BOIS MASSIF

- noyer américain
- rouvre brossé naturel
- rouvre brossé gris anthracite

CRISTAL

- traité à l'acide noir
- extra-clair traité à l'acide blanc
- transparent extra-clair (pas disponible pour 220, 280 cm)

CÉRAMIQUE BRILLANT pas Ø160 cm, Ø180 cm

- Calacatta
- Paonazzetto

MARBRE BRILLANT OU OPAQUE

- Calacatta
- Carrara
- Marquinia
- Emperador

② FINITURA BASE / BASE FINISH / BASIS AUSFÜHRUNG / FINITION BASE

VERNICIATO OPACO

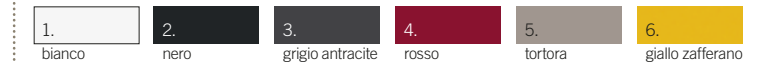

METALLO FINITURA



MAT PAINTED

- white
- black
- anthracite grey
- red
- dove grey
- safron yellow
- green
- blue
- bordeaux

LACKIERT MATT

- Weiss
- Schwarz
- Anthrazitgrau
- Rot
- Taubengrau
- Safrangelb
- Grün
- Blau
- Bordeaux

VERNI OPAQUE

- blanc
- noir
- gris anthracite
- rouge
- gris tourterelle
- jaune safran
- vert
- bleu
- bordeaux

METALL AUSFÜHRUNG

- Kupfer
- Messing
- Stahlgrau

FINITION MÉTAL

- couvre
- laiton
- décapé

DIMENSIONI / DIMENSIONS / GRÖßEN / DIMENSIONS

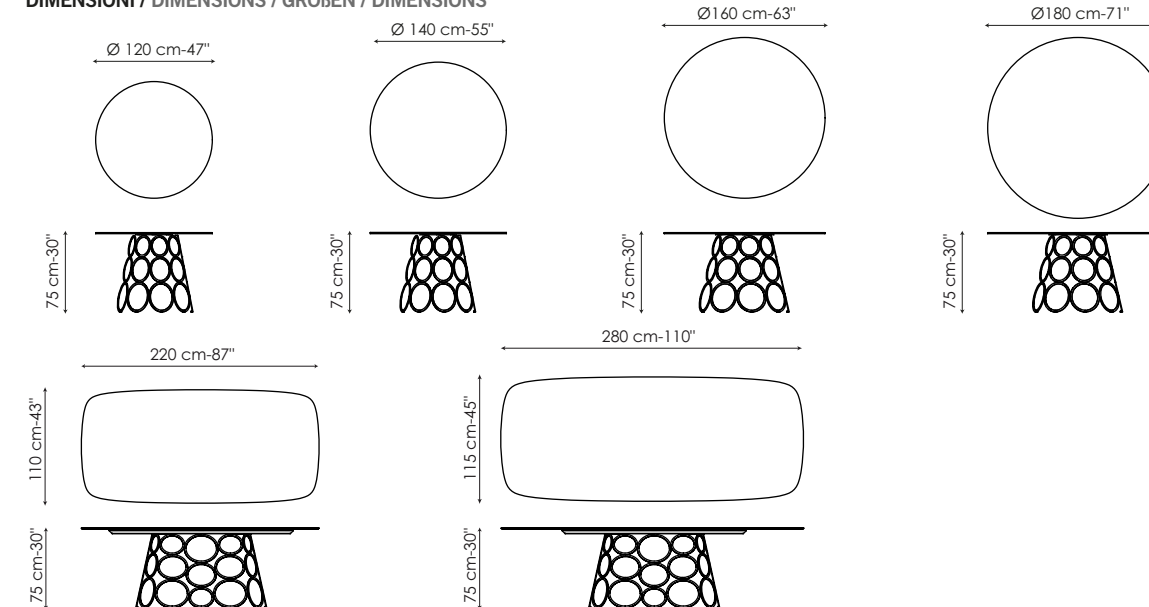

KIME

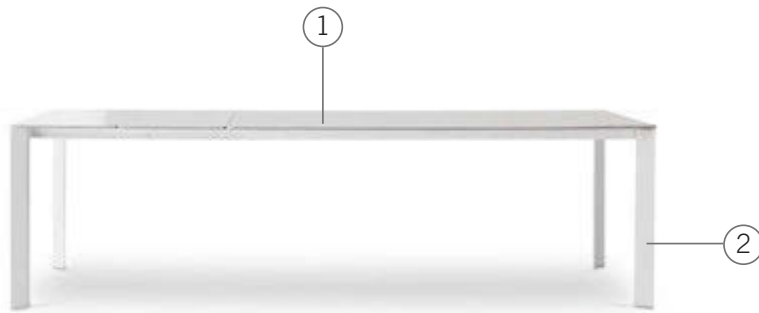

1
FINITURA PIANO E PROLUNGHE / TOP AND EXTENSIONS FINISH / PLATTE UND VERLÄNGERUNGEN AUSFÜHRUNG / FINITION PLAN ET RALLONGES

CRISTALLO

- 1. extrachiaro vernic. bianca/ Doluflex® laminato bianco
- 2. cristallo acidato nero/ Doluflex® laminato grigio antracite
- 3. cristallo extrachiaro acid. bianco/ Doluflex® laminato bianco

DOLUFLEX®

- 4. laminato bianco
- 5. laminato grigio antracite

GLASS

- 1. extra-light glass painted white/Doluflex® white laminated
- 2. acid-treated black glass/ Doluflex® anthracite grey laminated
- 3. extra-light glass acid-treated white/Doluflex® white laminated

DOLUFLEX®

- 4. laminated white
- 5. laminated anthracite grey

GLAS

- 1. Glas extra-hell Weiss lackiert/Doluflex® Laminat Weiss
- 2. Geätztes Glas Schwarz/ Doluflex® Laminat Anthrazitgrau
- 3. Geätztes Glas extra-hell Weiss/Doluflex® Laminat Weiss

DOLUFLEX®

- 4. Laminat Weiss
- 5. Laminat Anthrazitgrau

VERNI

- 1. cristal extra-clair verni blanc/Doluflex® laminé blanc
- 2. cristal traité à l'acide noir/ Doluflex® laminé gris anthracite
- 3. cristal extra-clair traité à l'acide blanc/Doluflex® laminé blanc

DOLUFLEX®

- 4. laminé blanc
- 5. laminé gris anthracite

2
FINITURA GAMBE / LEGS FINISH / BEINE AUSFÜHRUNG / FINITION PIEDS

VERNICIATO OPACO

- 1. bianco
- 2. grigio antracite

MAT PAINTED

- 1. white
- 2. anthracite grey

MATT LACKIERT

- 1. Weiss
- 2. Anthrazitgrau

VERNI OPAQUE

- 1. blanc
- 2. gris anthracite

DIMENSIONI / DIMENSIONS / GRÖßEN / DIMENSIONS

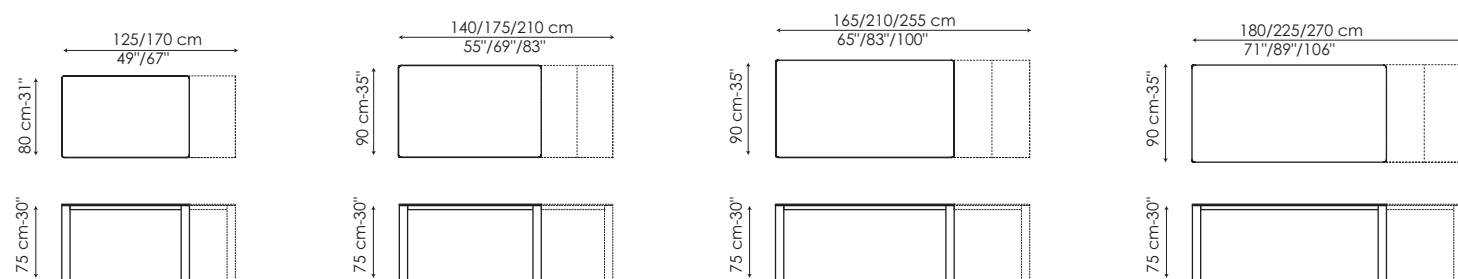

MASS TABLE



1
FINITURA PIANO / TOP FINISH / PLATTE AUSFÜHRUNG / FINITION PLAN

LEGNO MASSELLO

- 1. noce americano
- 2. rovere spazzolato naturale
- 3. rovere spazzolato grigio antracite

CRISTALLO

- 4. acidato nero
- 5. extrachiaro acidato bianco

CERAMICA LUCIDA (solo Ø140 cm)

- 6. Calacatta
- 7. Paonazzetto

MARMO LUCIDO O OPACO

- 8. Calacatta
- 9. Carrara
- 10. Marquinia
- 11. Emperador

SOLID WOOD

- 1. American walnut
- 2. natural polished oak
- 3. anthracite grey polished oak

GLASS

- 4. acid-treated black
- 5. extra light acid-treated white

GLOSSY CERAMIC only Ø140 cm

- 6. Calacatta
- 7. Paonazzetto

GLOSSY OR MAT MARBLE

- 8. Calacatta
- 9. Carrara
- 10. Marquinia
- 11. Emperador

MASSIVHOLZ

- 1. Amerikaner Nussbaum
- 2. Eiche Natur poliert
- 3. Eiche Anthrazitgrau poliert

GLAS

- 4. Geätztes Schwarz
- 5. Geätztes extra-hell Weiss

GLÄNZEND KERAMIC nur für Ø140 cm

- 6. Calacatta
- 7. Paonazzetto

GLÄNZEND ODER MATT MARMOR

- 8. Calacatta
- 9. Carrara
- 10. Marquinia
- 11. Emperador

BOIS MASSIF

- 1. noyer américain
- 2. rouvre brossé naturel
- 3. rouvre brossé gris anthracite

CRISTAL

- 4. traité à l'acide noir
- 5. extra-clair traité à l'acide blanc

CÉRAMIQUE BRILLANT seulement Ø140 cm

- 6. Calacatta
- 7. Paonazzetto

MARBRE BRILLANT OU OPAQUE

- 8. Calacatta
- 9. Carrara
- 10. Marquinia
- 11. Emperador

2
FINITURA BASE / BASE FINISH / BASIS AUSFÜHRUNG / FINITION BASE

VERNICIATO OPACO

- 1. bianco
- 2. nero
- 3. grigio antracite
- 4. rosso
- 5. tortora
- 6. giallo zafferano

- 7. verde
- 8. blu
- 9. bordeaux
- 10. coffee brown
- 11. racing green

METALLO FINITURA

- 12. rame opaco
- 13. ottone opaco

MAT PAINTED

- 1. white
- 2. black
- 3. anthracite grey
- 4. red
- 5. dove grey
- 6. saffron yellow
- 7. green
- 8. blue
- 9. bordeaux
- 10. coffee brown
- 11. racing green

METAL FINISH

- 12. mat copper
- 13. mat brass

LACKIERT MATT

- 1. Weiss
- 2. Schwarz
- 3. Anthrazitgrau
- 4. Rot
- 5. Taubengrau
- 6. Saafengelb
- 7. Grün
- 8. Blau
- 9. Bordeaux
- 10. Coffee Brown
- 11. Racing Green

METALL AUSFÜHRUNG

- 12. Kupfer matt
- 13. Messing matt

VERNI OPAQUE

- 1. blanc
- 2. noir
- 3. gris anthracite
- 4. rouge
- 5. gris tourterelle
- 6. jaune safran
- 7. vert
- 8. bleu
- 9. bordeaux
- 10. coffee brown
- 11. racing green

FINITION MÉTAL

- 12. cuivre opaque
- 13. laiton opaque

DIMENSIONI / DIMENSIONS / GRÖßEN / DIMENSIONS

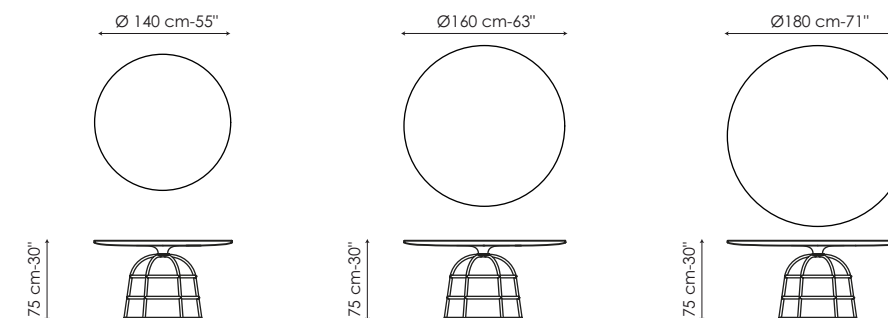

MATCH

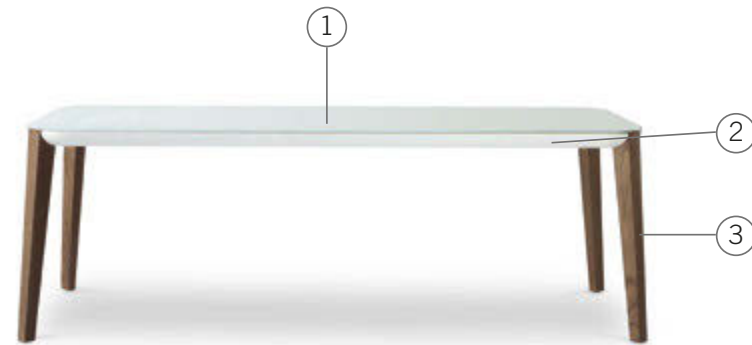

①

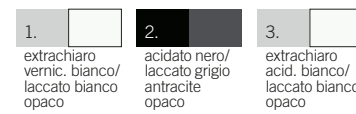
FINITURA PIANO E PROLUNGHE / TOP AND EXTENSIONS FINISH / PLATTE UND VERLÄNGERUNGEN AUSFÜHRUNG / FINITION PLAN ET RALLONGES
CRISTALLO

- GLASS**
1. extra-light glass painted white/mat lacquered white
 2. acid-treated black glass/mat lacquered anthracite grey
 3. extra-light glass acid-treated white/mat lacquered white

DOLUFLEX®

4. matt lacquered white
5. matt lacquered anthracite grey

GLAS

1. Glas extra-hell Weiss lackiert/Lackiert Weiss matt
2. Geätztes Glas Schwarz/Lackiert Anthrazitgrau matt
3. Geätztes Glas extra-hell Weiss/Lackiert Weiss matt

DOLUFLEX®

4. Lackiert Weiss matt
5. Lackiert Anthrazitgrau matt

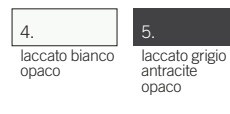
DOLUFLEX®**CRISTAL**

1. cristal extra-clair verni blanc/laqué blanc opaque
2. cristal traité à l'acide noir/laqué gris anthracite opaque
3. cristal extra-clair traité à l'acide blanc/laqué blanc opaque

DOLUFLEX®

4. laqué blanc opaque
5. laqué gris anthracite opaque

③

FINITURA GAMBE / LEGS FINISH / BEINE AUSFÜHRUNG / FINITION PIEDS
LEGNO MASSELLO**SOLID WOOD**

1. ash polished white
2. ash polished grey
3. walnut painted ash

MASSIVHOLZ

1. Eschen Weiss poliert
2. Eschen Grau poliert
3. Esche nussbaumfarbig lackiert

BOIS MASSIF

1. frêne blanc brossé
2. frêne gris brossé
3. frêne teinté noyer

②

FINITURA STRUTTURA PERIMETRALE / PERIMETRIC FRAME FINISH / ÄUSSENPROFIL AUSFÜHRUNG / FINITION STRUCTURE PÉRIMÉTRALE
LEGNO LACCATO OPACO in tinta con il piano**MAT LACQUERED WOOD**

- in tinta con il piano*
1. white
 2. anthracite grey

MATT HOLZ LACKIERT

- hat dieselbe Farbe der Platte*
1. Weiss
 2. Anthrazitgrau

BOIS LAQUÉ

- de la même couleur que le plan*
1. blanc
 2. anthracite

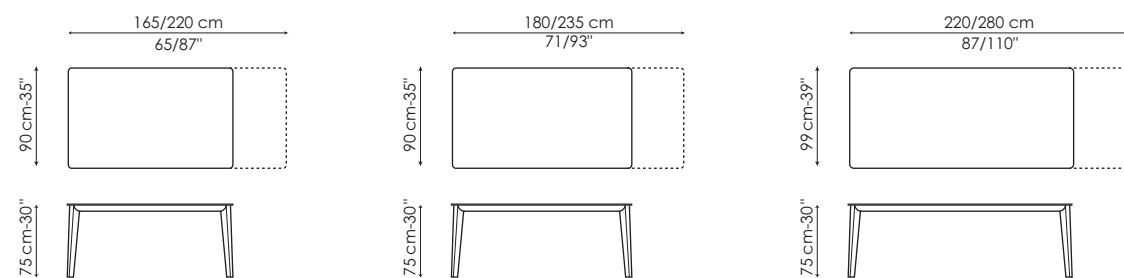
DIMENSIONI / DIMENSIONS / GRÖßEN / DIMENSIONS

MEDLEY

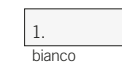

①

FINITURA PIANO / TOP FINISH / PLATTE AUSFÜHRUNG / FINITION PLAN
LACCATO OPACO**CERAMICA LUCIDA****MARMO LUCIDO O OPACO****MAT LACQUERED**

1. white

GLASS

2. acid-treated black
3. extra light acid-treated white

GLOSSY CERAMIC

4. Calacatta
5. Paonazzetto

GLOSSY OR MAT MARBLE

6. Calacatta
7. Carrara
8. Marquinia
9. Emperador

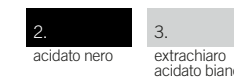
CRISTALLO**MATT LACKIERT**

1. Weiss

GLAS

2. Geätztes Schwarz
3. Geätztes extra-hell Weiss

GLÄNZEND KERAMIC

4. Calacatta
5. Paonazzetto

MARMOR GLÄNZEND ODER MATTI

6. Calacatta
7. Carrara
8. Marquinia
9. Emperador

LAQUÉ OPAQUE

1. blanc

CRISTAL

2. traité à l'acide noir
3. extra-clair traité à l'acide blanc

CÉRAMIQUE BRILLANT

4. Calacatta
5. Paonazzetto

MARBRE BRILLANT OU OPAQUE

6. Calacatta
7. Carrara
8. Marquinia
9. Emperador

②

FINITURA STRUTTURA / BASE FINISH / BASIS AUSFÜHRUNG / FINITION PIEDS
LEGNO MASSELLO**SOLID WOOD**

1. American walnut (not polished)
2. ash natural
3. ash grey

MASSIVHOLZ

1. Amerikaner Nussbaum (nicht poliert)
2. Esche Natur
3. Esche Grau

BOIS MASSIF

1. noyer américain (pas brossé)
2. frêne naturel
3. frêne gris

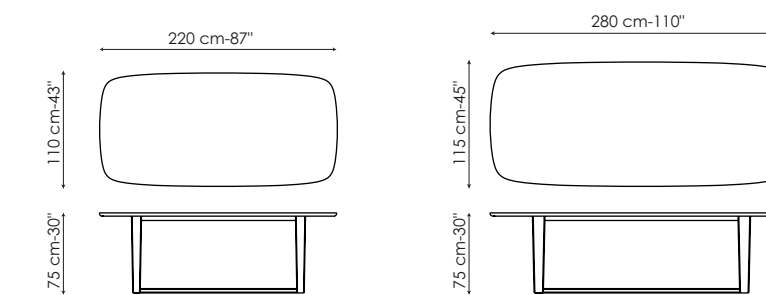
DIMENSIONI / DIMENSIONS / GRÖßEN / DIMENSIONS

MENÙ

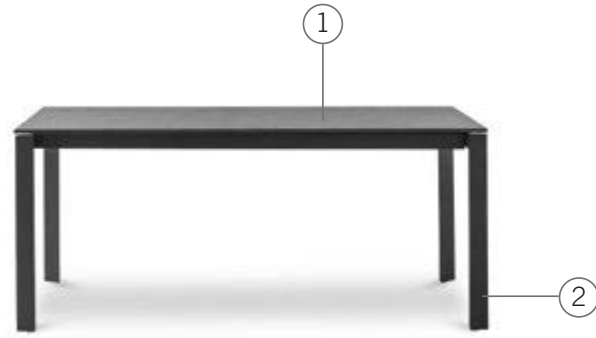

① **FINITURA PIANO E PROLUNGHE / TOP AND EXTENSIONS FINISH / PLATTE UND VERLÄNGERUNGEN AUSFÜHRUNG / FINITION PLAN ET RALLONGES**

LACCATO OPACO ad elevata resistenza superficiale



CRISTALLO ad elevata resistenza superficiale



CERAMICA OPACA



MAT LACQUERED
high surface resistance

1. white/ white lacquered
2. anthracite grey/ anthracite grey lacquered

GLASS
high surface resistance

3. acid-treated anthracite/ anthracite grey lacquered
4. extra-light glass acid-treated white/ white lacquered

MAT CERAMIC

5. graphite grey/ anthracite grey lacquered
6. iridium white/white lacquered

LACKIERT MATT
eine hohe Oberflächeneigenschaft

1. Weiss/ Lackiert Weiss
2. Anthrazitgrau/ Lackiert Anthrazitgrau

GLAS
eine hohe Oberflächeneigenschaft

3. Geätztes Anthrazitgrau/ Lackiert Anthrazitgrau
4. Geätztes extra-hell Weiss/ Lackiert Weiss

MATT KERAMIC

5. Graphitgrau/ Lackiert Anthrazitgrau
6. Iridium Weiss/ Lackiert Weiss

LAQUÉ OPAQUE
résistance de surface élevée

1. blanc/ laqué blanc
2. gris anthracite/ laqué gris anthracite

CRISTAL
résistance de surface élevée

3. traité à l'acide gris anthracite/laqué gris anthracite
4. extra-clair traité à l'acide blanc/laqué blanc

CÉRAMIQUE OPAQUE

5. gris graphite/ laqué gris anthracite
6. blanc iridium/ laqué blanc

② **FINITURA STRUTTURA / FRAME FINISH / STRUKTUR AUSFÜHRUNG / FINITION STRUCTURE**

VERNICIATO OPACO



MAT PAINTED

1. white
2. anthracite grey
3. dove grey

LACKIERT MATT

1. Weiss
2. Anthrazitgrau
3. Taubengrau

VERNI OPAQUE

1. blanc
2. gris anthracite
3. gris tourterelle

DIMENSIONI / DIMENSIONS / GRÖßEN / DIMENSIONS

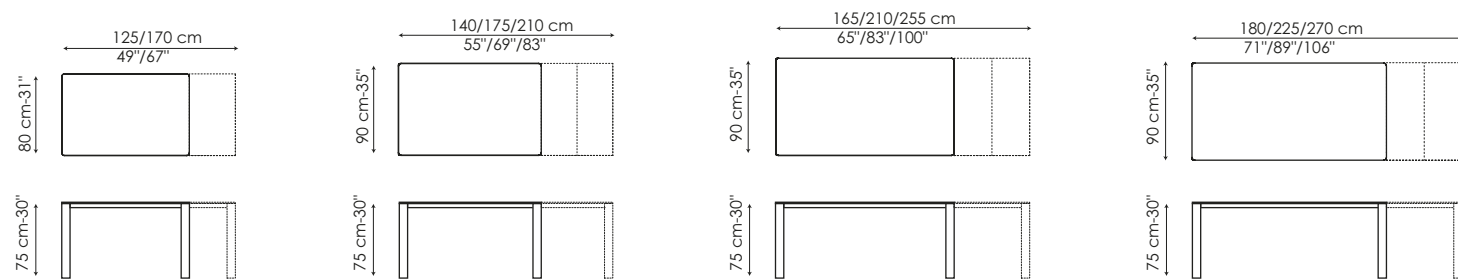

MILLE

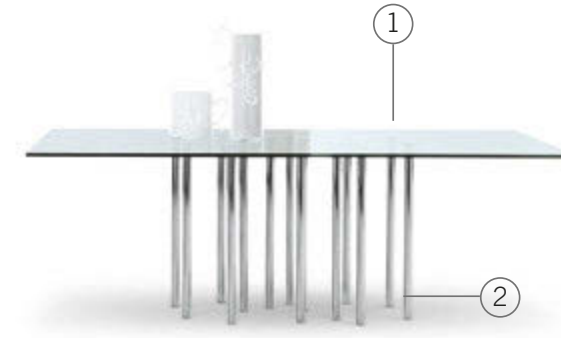

① **FINITURA PIANO / TOP FINISH / PLATTE AUSFÜHRUNG / FINITION PLAN**

CRISTALLO

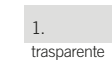

GLASS
1. transparent glass

GLAS
1. Klarglas

CRISTAL
1. cristal transparent

② **FINITURA GAMBE / LEGS FINISH / BEINE AUSFÜHRUNG / FINITION PIEDS**

METALLO

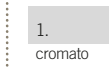

METAL FINISH
1. chromed

METALL AUSFÜHRUNG
1. Verchromt

FINITION MÉTAL
1. chromé

DIMENSIONI / DIMENSIONS / GRÖßEN / DIMENSIONS

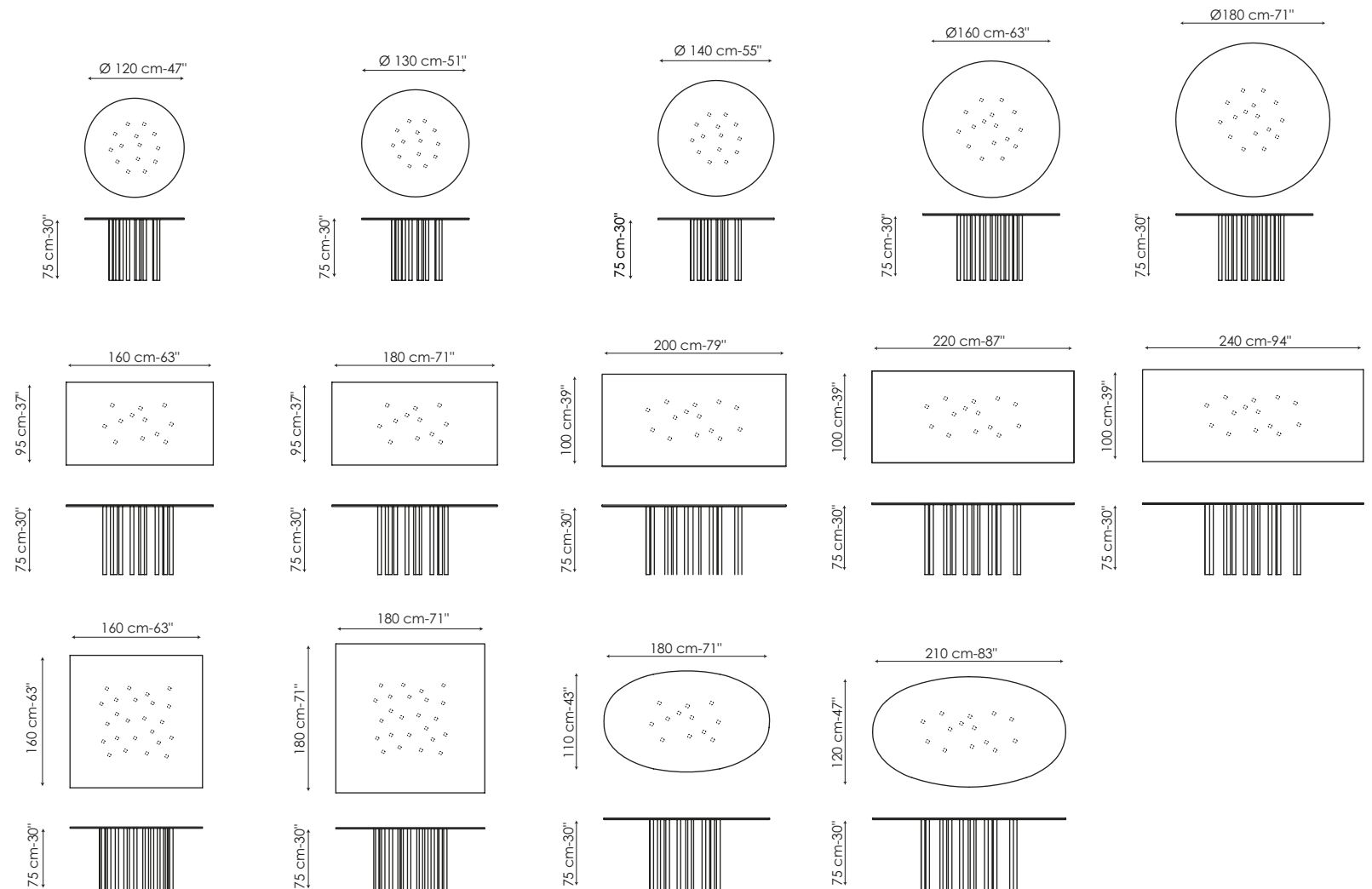

OCTA FISSO / FIXED / FEST / FIXE



① FINITURA PIANO / TOP FINISH / PLATTE AUSFÜHRUNG / FINITION PLAN

LACCATO



LEGGNO CON BORDI NATURALI

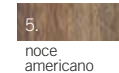

CERAMICA OPACA



LEGGNO MASSELLO

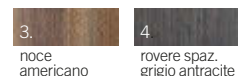

CRISTALLO

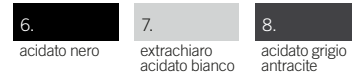

CERAMICA LUCIDA



LACQUERED

- 1. mat white
- 2. mat anthracite grey

SOLID WOOD

- 3. American walnut
- 4. anthracite grey brushed oak

WOOD WITH NATURAL EDGES

- 5. American walnut

GLASS

- 6. acid-treated black
- 7. extra-light acid treated white
- 8. acid-treated anthracite grey

MAT CERAMIC

- 9. iridium white
- 10. graphite grey

GLOSSY CERAMIC

- 11. Calacatta
- 12. Paonazzetto

LACKIERT

- 1. Weiss matt
- 2. Anthrazitgrau matt

MASSIVHOLZ

- 3. Amerikaner Nussbaum
- 4. Eiche Anthrazitgrau poliert

HOLZ MIT WALDKANTE

- 5. Amerikaner Nussbaum

GLAS

- 6. Geätztes Schwarz
- 7. Geätztes extra-hell Weiss
- 8. Geätztes Anthrazitgrau

MATT KERAMIC

- 9. Iridium Weiss
- 10. Graphitgrau

GLÄNZEND KERAMIC

- 11. Calacatta
- 12. Paonazzetto

LAQUÉ

- 1. blanc opaque
- 2. gris anthracite opaque

BOIS MASSIF

- 3. noyer américain
- 4. rouvre brossé gris anthracite

BOIS AVEC CONTOUR NATUREL

- 5. noyer américain

CRISTAL

- 6. traité à l'acide noir
- 7. extra-clair traité à l'acide blanc
- 8. traité à l'acide gris anthracite

CÉRAMIQUE OPAQUE

- 9. blanc iridium
- 10. gris graphite

CÉRAMIQUE BRILLANT

- 11. Calacatta
- 12. Paonazzetto

② FINITURA BASE / BASE FINISH / BASIS AUSFÜHRUNG / FINITION BASE

VERNICIATO OPACO



METALLO FINITURA



MAT PAINTED

- 1. white
- 2. anthracite grey
- 3. bordeaux
- 4. dove grey
- 5. brown

MATT LACKIERT

- 1. Weiss
- 2. Anthrazitgrau
- 3. Bordeaux
- 4. Taubengrau
- 5. Braun

VERNI OPAQUE

- 1. blanc
- 2. gris anthracite
- 3. bordeaux
- 4. gris tourterelle
- 5. marron

METAL FINISH

- 6. chromed
- 7. black nickel

METALL AUSFÜHRUNG

- 6. Verchromt
- 7. Schwarz vernickelt

FINITION MÉTAL

- 6. chromé
- 7. noir nickel

DIMENSIONI / DIMENSIONS / GRÖßEN / DIMENSIONS

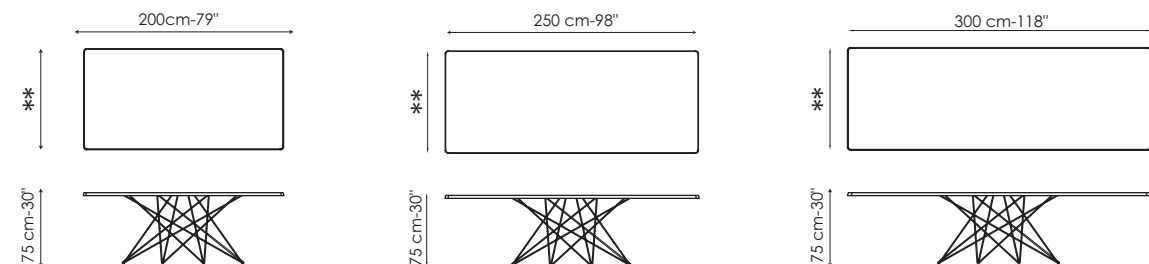

** 100 cm – 39.4"
legno, ceramica / wood, ceramic / Holz, Keramic / bois, céramique
99 cm – 39"
cristallo / glass / glas / cristal

** 100 cm – 39.4"
massello, laccato, cristallo, ceramica / solid, lacquered, glass, ceramic / Massivholz, lackiert, Glas, Keramic / massif, laqué, cristal, céramique
110 cm – 43.3"
legno con bordi naturali / wood with natural edges / Holz mit Waldkante / bois avec contour naturel

** 108 cm – 42.5"
massello, laccato, cristallo, ceramica lucida / solid, lacquered, glass, glossy ceramic / Massivholz, lackiert, Glas, glänzend
Keramic / massif, laqué, cristal, céramique brillante
100 cm – 39.4"
ceramica opaca / mat ceramic / matt Keramic / céramique opaque
120 cm – 47.2"
legno con bordi naturali / wood with natural edges / Holz mit Waldkante / bois avec contour naturel

OCTA FISSO / FIXED / FEST / FIXE



① FINITURA PIANO / TOP FINISH / PLATTE AUSFÜHRUNG / FINITION PLAN

CRISTALLO

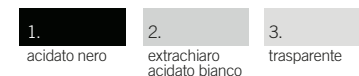

GLASS

- 1. acid-treated black
- 2. extra-light acid treated white
- 3. transparent

GLAS

- 1. Geätztes Schwarz
- 2. Geätztes extra-hell Weiss
- 3. Klarglas

CRISTAL

- 1. traité à l'acide noir
- 2. extra-clair traité à l'acide blanc
- 3. transparent

② FINITURA BASE / BASE FINISH / BASIS AUSFÜHRUNG / FINITION BASE

VERNICIATO OPACO



METALLO FINITURA



MAT PAINTED

- 1. white
- 2. anthracite grey
- 3. bordeaux
- 4. dove grey
- 5. brown

MATT LACKIERT

- 1. Weiss
- 2. Anthrazitgrau
- 3. Bordeaux
- 4. Taubengrau
- 5. Braun

VERNI OPAQUE

- 1. blanc
- 2. gris anthracite
- 3. bordeaux
- 4. gris tourterelle
- 5. marron

METAL FINISH

- 6. chromed
- 7. black nickel

METALL AUSFÜHRUNG

- 6. Verchromt
- 7. Schwarz vernickelt

FINITION MÉTAL

- 6. chromé
- 7. noir nickel

DIMENSIONI / DIMENSIONS / GRÖßEN / DIMENSIONS

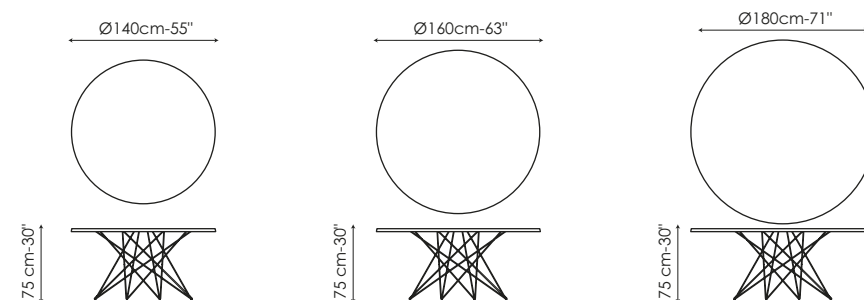

OCTA ALLUNGABILE / EXTENDABLE / AUSZIEHBAR / EXTENSIBLE



1
FINITURA PIANO E PROLUNGHE / TOP AND EXTENSIONS FINISH / PLATTE UND VERLÄNGERUNGEN AUSFÜHRUNG / FINITION PLAN ET RALLONGES

CRISTALLO

- 1. acidato nero/laccato nero opaco*
- 2. extrachiari acidato bianco/laccato bianco opaco*

CERAMICA OPACA

- 3. bianco iridium
- 4. grigio grafite

CERAMICA LUCIDA

- 5. Calacatta
- 6. Paonazzetto

GLASS

- 1. acid-treated black/lacquered mat black*
- 2. extra-light acid treated white/lacquered mat white*

MAT CERAMIC

- 3. iridium white
- 4. graphite grey

GLOSSY CERAMIC

- 5. Calacatta
- 6. Paonazzetto

GLAS

- 1. Geätztes Schwarz/Lackiert Schwarz matt*
- 2. Geätztes extra-hell Weiss/Lackiert Weiss matt*

MATT KERAMIC

- 3. Iridium Weiss
- 4. Graphitgrau

GLÄNZEND KERAMIC

- 5. Calacatta
- 6. Paonazzetto

CRISTAL

- 1. traité à l'acide noir/laqué noir opaque*
- 2. extra-clair traité à l'acide blanc/laqué blanc opaque*

CÉRAMIQUE OPAQUE

- 3. blanc iridium
- 4. gris graphite

CÉRAMIQUE BRILLANT

- 5. Calacatta
- 6. Paonazzetto

2
FINITURA BASE / BASE FINISH / BASIS AUSFÜHRUNG / FINITION BASE

VERNICIATO OPACO

- 1. bianco
- 2. grigio antracite
- 3. bordeaux
- 4. tortora
- 5. marrone

METALLO FINITURA

- 6. cromato
- 7. black nickel

MATT PAINTED

- 1. white
- 2. anthracite grey
- 3. bordeaux
- 4. dove grey
- 5. brown

METAL FINISH

- 6. chromed
- 7. black nickel

MATT LACKIERT

- 1. Weiss
- 2. Anthrazitgrau
- 3. Bordeaux
- 4. Taubengrau
- 5. Braun

METALL AUSFÜHRUNG

- 6. Verchromt
- 7. Schwarz vernickelt

VERNI OPAQUE

- 1. blanc
- 2. gris anthracite
- 3. bordeaux
- 4. gris tourterelle
- 5. marron

FINITION MÉTAL

- 6. chromé
- 7. noir nickel

DIMENSIONI / DIMENSIONS / GRÖßEN / DIMENSIONS

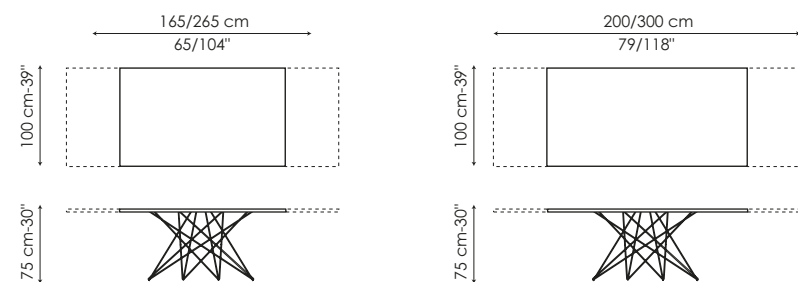

* prolunga disponibile anche in cristallo
* extension also available in glass
* Verlängerung verfügbar auch auf Glas
* rallonge disponible aussi en cristal

STILL



1
FINITURA PIANO / TOP FINISH / PLATTE AUSFÜHRUNG / FINITION PLAN

LACCATO OPACO

- 1. bianco

LEGNO MASSELLO

- 2. noce americano

MATT PAINTED

- 1. white

SOLID WOOD

- 2. American walnut

MATT LACKIERT

- 1. Weiss

MASSIVHOLZ

- 2. Amerikaner Nussbaum

VERNI OPAQUE

- 1. blanc

BOIS MASSIF

- 2. noyer américain

2
FINITURA GAMBE / LEGS FINISH / BEINE AUSFÜHRUNG / FINITION PIEDS

- 1. cemento

- 1. cement

- 1. Sichtbeton

- 1. ciment

DIMENSIONI / DIMENSIONS / GRÖßEN / DIMENSIONS

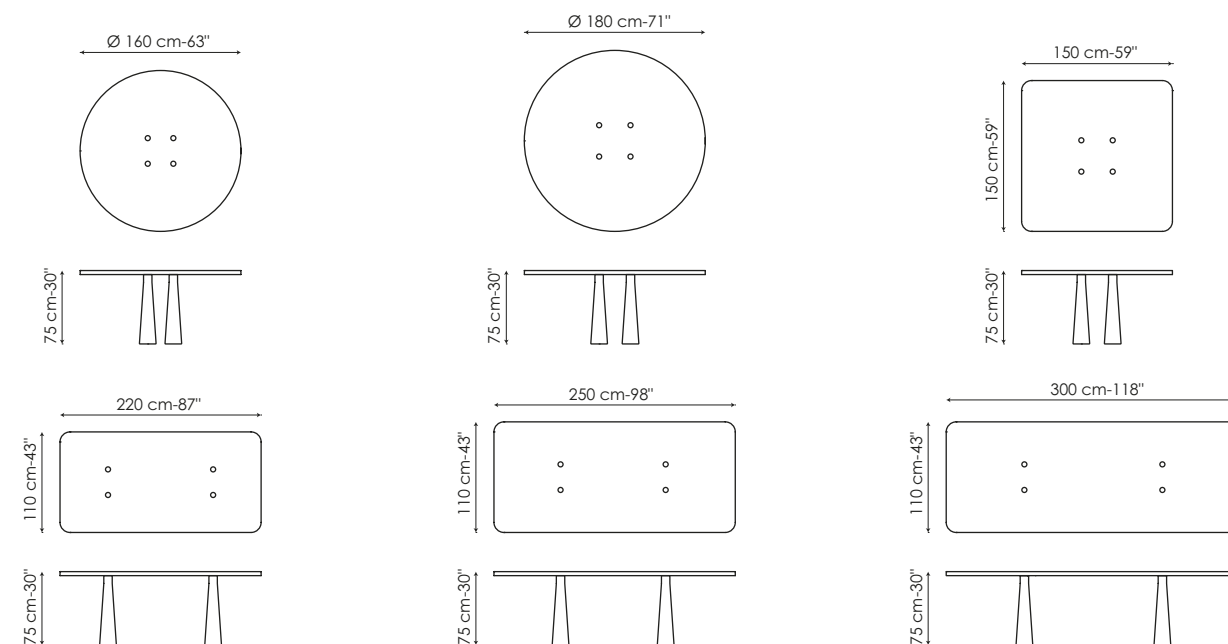

PRORA FISSO / FIXED / FEST / FIXE



①

FINITURA PIANO / TOP FINISH / PLATTE AUSFÜHRUNG / FINITION PLAN

CRISTALLO

- | | |
|-----------------|-----------------------------|
| 1. acidato nero | 2. extrachiaro acid. bianco |
|-----------------|-----------------------------|

LEGNO MASSELLO

- | | |
|-------------|-------------------|
| 3. noce 400 | 4. noce americano |
|-------------|-------------------|

LEGNO MASSELLO CON NODI

- | |
|-------------------------------|
| 5. rovere spazzolato naturale |
|-------------------------------|

LEGNO IMPIALLACCIATO

- | | | | |
|-------------------|--------------------|----------------------------|-------------------------|
| 6. noce canaletto | 7. rovere naturale | 8. rovere grigio antracite | 9. rovere termotrattato |
|-------------------|--------------------|----------------------------|-------------------------|

GLASS

- acid-treated black
- extra-light acid-treated white

GLAS

- Geätztes Schwarz
- Geätztes extra-hell Weiss

CRISTAL

- cristal traité à l'acide noir
- cristal extra-clair traité à l'acide blanc

SOLID WOOD

- walnut 400
- American walnut

MASSIVHOLZ

- Nussbaum 400
- Amerikaner Nussbaum

BOIS MASSIF

- noyer 400
- noyer américain

SOLID WOOD WITH KNOTS

- natural polished oak

MASSIVHOLZ MIT KNOTEN

- Eiche Natur poliert

BOIS MASSIF AVEC NOEUDS

- rouvre brossé naturel

VENEREED WOOD

- Canaletto walnut
- natural oak
- anthracite grey oak
- heat-treated oak

HOLZ FURNIERT

- Nussbaum Canaletto
- Eiche Natur
- Eiche Anthrazitgrau
- thermo-behandelte Eiche

BOIS PLAQUÉ

- noyer Canaletto
- rouvre naturel
- rouvre gris anthracite
- rouvre traité thermiquement

②

FINITURA GAMBE / LEGS FINISH / BEINE AUSFÜHRUNG / FINITION PIEDS

VERNICIATO

- | | | |
|------------------|-----------------|---------------------------|
| 1. bianco lucido | 2. bianco opaco | 3. grigio antracite opaco |
|------------------|-----------------|---------------------------|

METALLO FINITURA

- | | |
|-----------------------|-------------|
| 4. acciaio spazzolato | 5. decapato |
|-----------------------|-------------|

PAINTED

- glossy white
- mat white
- mat anthracite grey

LACKIERT

- Weiss glänzend
- Weiss matt
- Anthrazitgrau matt

VERNI

- blanc brillant
- blanc opaque
- gris anthracite opaque

METAL FINISH

- polished steel
- pickled

METALL AUSFÜHRUNG

- Stahl poliert
- Stahlgrau

MÉTAL FINITION

- acier brossé
- décapé

DIMENSIONI / DIMENSIONS / GRÖßEN / DIMENSIONS

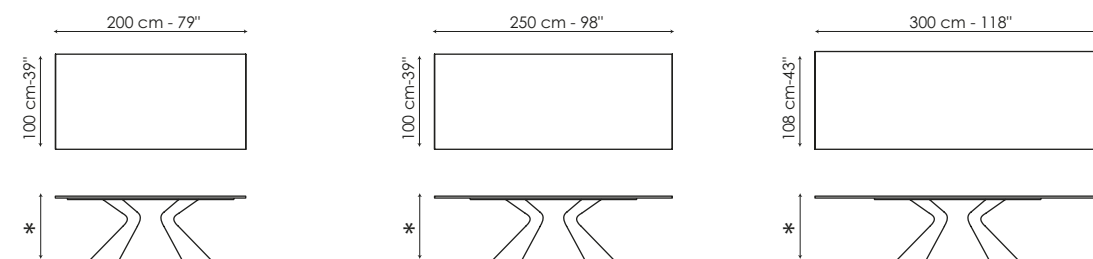

* 76 cm – 29.9"
legno / wood / Holz / bois
75,5 cm – 29.7"
cristallo / glass / glas / cristal

PRORA ALLUNGABILE / EXTENDABLE / AUSZIEHBAR / EXTENSIBLE

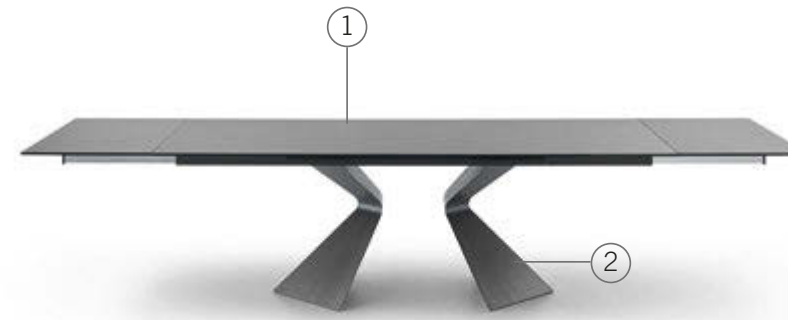

①

FINITURA PIANO E PROLUNGHE / TOP AND EXTENSIONS FINISH / PLATTE UND VERLÄNGERUNGEN AUSFÜHRUNG / FINITION PLAN ET RALLONGES

CRISTALLO

- | | | |
|-------------------------------|-----------------|-----------------------------|
| 1. extrachiaro vernic. bianco | 2. acidato nero | 3. extrachiaro acid. bianco |
|-------------------------------|-----------------|-----------------------------|

GLASS

- extra-light glass painted white
- acid-treated black glass
- extra-light glass acid-treated white

GLAS

- Glas extra-hell Weiss lackiert
- Geätztes Glas Schwarz
- Geätztes Glas extra-hell Weiss

CRISTAL

- cristal extra-clair verni blanc
- cristal traité à l'acide noir
- cristal extra-clair traité à l'acide blanc

②

FINITURA GAMBE / LEGS FINISH / BEINE AUSFÜHRUNG / FINITION PIEDS

VERNICIATO

- | | | |
|------------------|-----------------|---------------------------|
| 1. bianco lucido | 2. bianco opaco | 3. grigio antracite opaco |
|------------------|-----------------|---------------------------|

METALLO FINITURA

- | | |
|-----------------------|-------------|
| 4. acciaio spazzolato | 5. decapato |
|-----------------------|-------------|

PAINTED

- glossy white
- mat white
- mat anthracite grey

LACKIERT

- Weiss glänzend
- Weiss matt
- Anthrazitgrau matt

VERNI

- blanc brillant
- blanc opaque
- gris anthracite opaque

METAL FINISH

- polished steel
- pickled

METALL AUSFÜHRUNG

- Stahl poliert
- Stahlgrau

MÉTAL FINITION

- acier brossé
- décapé

DIMENSIONI / DIMENSIONS / GRÖßEN / DIMENSIONS

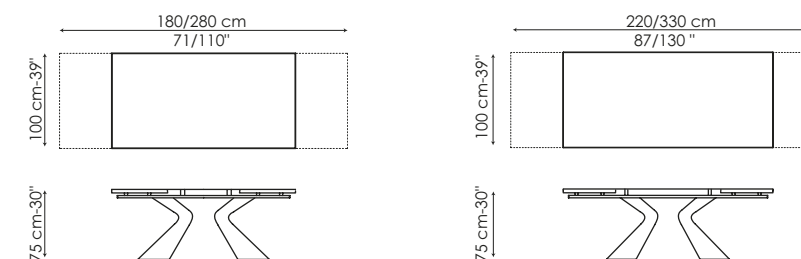

SOL FISSO / FIXED / FEST / FIXE

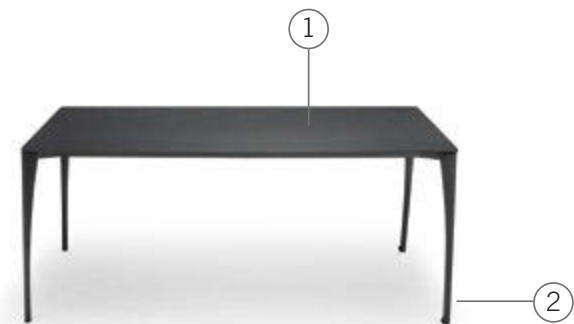

1
FINITURA PIANO / TOP FINISH / PLATTE AUSFÜHRUNG / FINITION PLAN

CRISTALLO

- 1. extrachiaro vernic. bianco
- 2. acidato nero
- 3. extrachiaro acid. bianco

DOLUFLEX®

- 4. laminato bianco
- 5. laminato grigio antracite

GLASS

- 1. extra-light glass painted white
- 2. acid-treated black glass
- 3. extra-light glass acid-treated white

GLAS

- 1. Glas extra-hell Weiss lackiert
- 2. Geätztes Glas Schwarz
- 3. Geätztes Glas extra-hell Weiss

CRISTAL

- 1. cristal extra-clair verni blanc
- 2. cristal traité à l'acide noir
- 3. cristal extra-clair traité à l'acide blanc

DOLUFLEX®

- 4. laminated white
- 5. laminated anthracite grey

DOLUFLEX®

- 4. Laminat Weiss
- 5. Laminat Anthrazitgrau

DOLUFLEX®

- 4. laminé blanc
- 5. laminé gris anthracite

2
FINITURA GAMBE / LEGS FINISH / BEINE AUSFÜHRUNG / FINITION PIEDS

PRESSOFUSIONE IN ALLUMINIO

- 1. verniciato bianco opaco
- 2. verniciato grigio antracite opaco
- 3. spazzolato

DIE-CAST ALUMINIUM

- 1. painted mat white
- 2. painted mat anthracite grey
- 3. polished

DRUCKGUSS ALUMINIUM

- 1. Lackiert Weiss matt
- 2. Lackiert Anthrazitgrau matt
- 3. Poliert

ALUMINIUM MOULÉ SOUS PRESSION

- 1. verni blanc opaque
- 2. verni gris anthracite opaque
- 3. brossé

DIMENSIONI / DIMENSIONS / GRÖßEN / DIMENSIONS

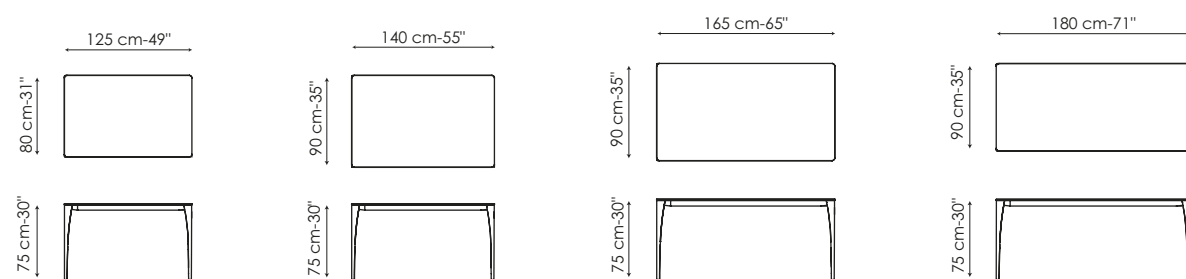

SOL ALLUNGABILE / EXTENDABLE / AUSZIEHBAR / EXTENSIBLE



1
FINITURA PIANO E PROLUNGHE / TOP AND EXTENSIONS FINISH / PLATTE UND VERLÄNGERUNGEN AUSFÜHRUNG / FINITION PLAN ET RALLONGES

CRISTALLO

- 1. cristallo extrachiaro vernic. bianco/Doluflex® laminato bianco
- 2. cristallo acidato nero/Doluflex® laminato grigio antracite
- 3. cristallo extrachiaro acid. bianco/Doluflex® laminato bianco

DOLUFLEX®

- 4. laminato bianco
- 5. laminato grigio antracite

GLASS

- 1. extra-light glass painted white/Doluflex® white laminated
- 2. acid-treated black glass/Doluflex® anthracite grey laminated
- 3. extra-light glass acid-treated white/Doluflex® white laminated

GLAS

- 1. Glas extra-hell Weiss lackiert/Doluflex® Laminat Weiss
- 2. Geätztes Glas Schwarz/Doluflex® Laminat Anthrazitgrau
- 3. Geätztes Glas extra-hell Weiss/Doluflex® Laminat Weiss

CRISTAL

- 1. cristal extra-clair verni blanc / Doluflex® laminé blanc
- 2. cristal traité à l'acide noir / Doluflex® laminé gris anthracite
- 3. cristal extra-clair traité à l'acide blanc / Doluflex® laminé blanc

DOLUFLEX®

- 4. laminated white
- 5. laminated anthracite grey

DOLUFLEX®

- 4. Laminat Weiss
- 5. Laminat Anthrazitgrau

DOLUFLEX®

- 4. laminé blanc
- 5. laminé gris anthracite

2
FINITURA GAMBE / LEGS FINISH / BEINE AUSFÜHRUNG / FINITION PIEDS

PRESSOFUSIONE IN ALLUMINIO

- 1. verniciato bianco opaco
- 2. verniciato grigio antracite opaco
- 3. spazzolato

DIE-CAST ALUMINIUM

- 1. painted mat white
- 2. painted mat anthracite grey
- 3. polished

DRUCKGUSS ALUMINIUM

- 1. Lackiert Weiss matt
- 2. Lackiert Anthrazitgrau matt
- 3. Poliert

ALUMINIUM MOULÉ SOUS PRESSION

- 1. verni blanc opaque
- 2. verni gris anthracite opaque
- 3. brossé

DIMENSIONI / DIMENSIONS / GRÖßEN / DIMENSIONS

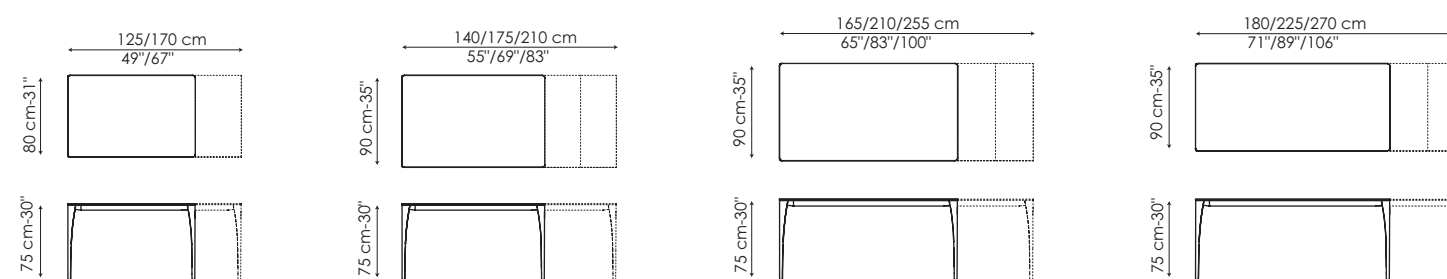

TL FISSO / FIXED / FEST / FIXE

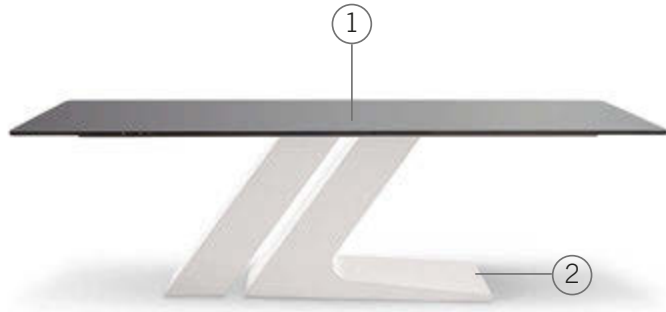

① FINITURA PIANO / TOP FINISH / PLATTE AUSFÜHRUNG / FINITION PLAN

LACCATO	IMPIALLACCIATO LEGNO
1. bianco opaco	2. noce canaletto
	3. rovere spazzolato naturale
	4. rovere spazzolato termotrattato
	5. rovere spaz. grigio antracite
LEGNO MASSICCIO	LEGNO CON BORDI NATURALI
6. noce americano	7. rovere spazzolato naturale
	8. rovere spaz. grigio antracite
	9. noce americano
CERAMICA LUCIDA	CERAMICA OPACA
13. Calacatta	14. Paonazzetto
	15. grigio grafite
	16. bianco iridium
	10. cristallo acidato nero
	11. extrachiaro acidato bianco
	12. acidato grigio antracite

LACQUERED	LACKIERT	LAQUÉ
1. mat white	1. Weiss matt	1. blanc opaque
VENEERED WOOD	HOLZ FURNIERT	BOIS PLAQUÉ
2. walnut canaletto	2. Nussbaum Canaletto	2. noyer canaletto
3. natural polished oak	3. Eiche Natur poliert	3. rovere brossé naturel
4. heat-treated polished oak	4. thermo-behandelte polierte Eiche	4. rovere brossé traité thermiquement
5. anthracite grey polished oak	5. Eiche Anthrazitgrau poliert	5. rovere brossé gris anthracite
SOLID WOOD	MASSIVHOLZ	BOIS MASSIF
6. American walnut	6. Amerikaner Nussbaum	6. noyer américain
7. natural polished oak	7. Eiche Natur poliert	7. rovere brossé naturel
8. anthracite grey polished oak	8. Eiche Anthrazitgrau poliert	8. rovere brossé gris anthracite
WOOD WITH NATURAL EDGES	HOLZ MIT WALDKANTE	BOIS AVEC CONTOUR NATUREL
9. American walnut	9. Amerikaner Nussbaum	9. noyer américain
GLASS	GLAS	CRISTALLO
10. acid-treated black	10. Geätztes Schwarz	10. traité à l'acide noir
11. extra-light acid treated white	11. Geätztes extra-hell Weiss	11. extra-clair traité à l'acide blanc
12. acid-treated anthracite	12. Geätztes Anthrazitgrau	12. traité à l'acide gris anthracite
GLOSSY CERAMIC	GLÄNZEND KERAMIC	CÉRAMIQUE BRILLANT
13. Calacatta	13. Calacatta	13. Calacatta
14. Paonazzetto	14. Paonazzetto	14. Paonazzetto
MAT CERAMIC	MATT KERAMIC	CÉRAMIQUE OPAQUE
15. graphite grey	15. Graphitgrau	15. gris graphite
16. iridium white	16. Iridium Weiss	16. blanc iridium

② FINITURA GAMBE / LEGS FINISH / BEINE AUSFÜHRUNG / FINITION PIEDS

VERNICIATO OPACO
1. bianco
2. nero
3. grigio antracite
4. rosso
5. tortora
6. giallo zafferano
7. verde
8. blu
9. bordeaux
METALLO FINITURA
10. rame
11. ottone
12. decapato

MAT PAINTED	LACKIERT MATT	VERNI OPAQUE
1. white	1. Weiss	1. blanc
2. black	2. Schwarz	2. noir
3. anthracite grey	3. Anthrazitgrau	3. gris anthracite
4. red	4. Rot	4. rouge
5. dove grey	5. Taubengrau	5. gris tourterelle
6. saffron yellow	6. Safrangelb	6. jaune safran
7. green	7. Grün	7. vert
8. blue	8. Blau	8. bleu
9. bordeaux	9. Bordeaux	9. bordeaux
METAL FINISH	METALL AUSFÜHRUNG	FINITION MÉTAL
10. copper	10. Kupfer	10. cuivre
11. brass	11. Messing	11. laiton
12. pickled	12. Stahlgrau	12. décapé

DIMENSIONI / DIMENSIONS / GRÖßEN / DIMENSIONS

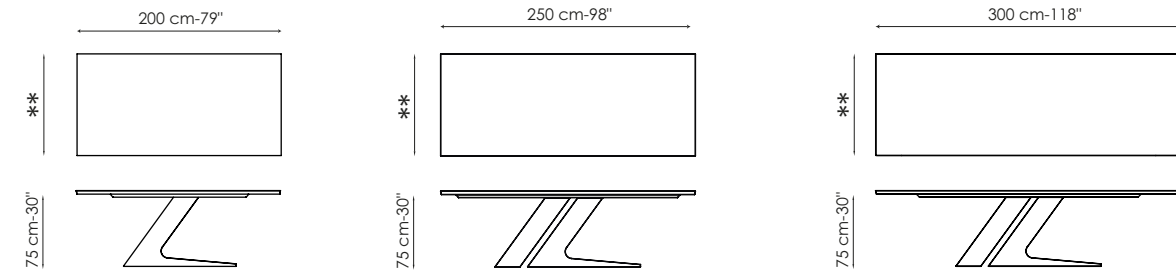

** 100 cm - 39.4"
legno, ceramica / wood, ceramic / Holz, Keramik / bois, céramique
99 cm - 39"
cristallo / glass / Glas / cristal

** 100 cm - 39.4"
massiccio, impiallacciato, laccato, cristallo, ceramica / solid, veneered, lacquered, glass, ceramic / Massivholz, furniert, lackiert, Glas, Keramik / massif plaqué, laqué, cristal, céramique brillante
110 cm - 43.3"
legno con bordi naturali / wood with natural edges / Holz mit Waldkante / bois avec contour naturel

TL ALLUNGABILE / EXTENDABLE / AUSZIEHBAR / EXTENSIBLE

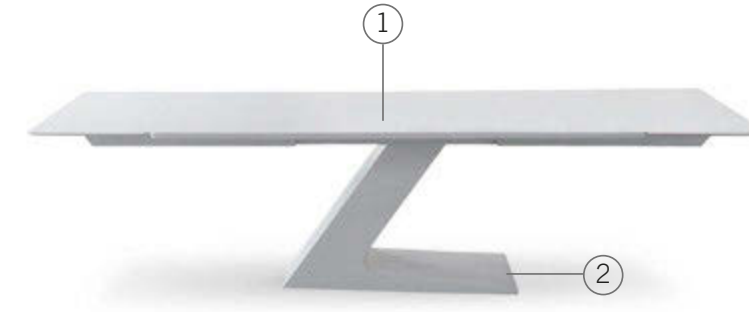

① FINITURA PIANO E PROLUNGHE / TOP AND EXTENSIONS FINISH / PLATTE UND VERLÄNGERUNGEN AUSFÜHRUNG / FINITION PLAN ET RALLONGES

LACCATO OPACO	IMPIALLACCIATO LEGNO solo per 200 cm
1. bianco	2. noce canaletto
	3. rovere spaz. grigio antracite
	4. rovere spazzolato naturale
	5. rovere spazzolato termotrattato
CRISTALLO	CERAMICA OPACA solo per 200 cm
6. acidato nero/laccato nero opaco*	9. bianco iridium
7. extrachiaro acidato bianco/laccato bianco opaco*	10. grigio grafite
8. acidato grigio antracite/laccato grigio antracite opaco*	
CERAMICA LUCIDA solo per 200 cm	
11. Calacatta	12. Paonazzetto

LACQUERED	LACKIERT	LAQUÉ
1. mat white	1. Weiss matt	1. blanc opaque
VENEERED WOOD only for 200 cm	HOLZ FURNIERT nur für 200 cm	BOIS PLAQUÉ seulement 200 cm
2. walnut canaletto	2. Nussbaum Canaletto	2. noyer canaletto
3. anthracite grey polished oak	3. Eiche Anthrazitgrau poliert	3. rovere brossé gris anthracite
4. natural polished oak	4. Eiche Natur poliert	4. rovere brossé naturel
5. heat-treated polished oak	5. thermo-behandelte polierte Eiche	5. rovere brossé traité thermiquement
GLASS	GLAS	CRISTALLO
6. acid-treated black/lacquered mat black*	6. Geätztes Schwarz/Lackiert Schwarz matt*	6. traité à l'acide noir/laqué noir opaque*
7. extra-light acid treated white/lacquered mat white*	7. Geätztes extra-hell Weiss/Lackiert Weiss matt*	7. extra-clair traité à l'acide blanc/laqué blanc opaque*
8. acid-treated anthracite grey/lacquered mat anthracite grey*	8. Geätztes Anthrazitgrau/Lackiert Anthrazitgrau mat*	8. traité à l'acide gris anthracite/laqué gris anthracite opaque*
MAT CERAMIC only for 200 cm	MATT KERAMIC nur für 200 cm	CÉRAMIQUE OPAQUE seulement 200 cm
9. white iridium	9. Weiss Iridium	9. blanc iridium
10. graphite grey	10. Graphitgrau	10. gris graphite
GLOSSY CERAMIC only for 200 cm	GLÄNZEND KERAMIC nur für 200 cm	CÉRAMIQUE BRILLANT seulement 200 cm
11. Calacatta	11. Calacatta	11. Calacatta
12. Paonazzetto	12. Paonazzetto	12. Paonazzetto

② FINITURA GAMBE / LEGS FINISH / BEINE AUSFÜHRUNG / FINITION PIEDS

VERNICIATO OPACO
1. bianco
2. nero
3. grigio antracite
4. rosso
5. tortora
6. giallo zafferano
7. verde
8. blu
9. bordeaux
METALLO FINITURA
10. rame
11. ottone
12. decapato

MAT PAINTED	LACKIERT MATT	VERNI OPAQUE
1. white	1. Weiss	1. blanc
2. black	2. Schwarz	2. noir
3. anthracite grey	3. Anthrazitgrau	3. gris anthracite
4. red	4. Rot	4. rouge
5. dove grey	5. Taubengrau	5. gris tourterelle
6. saffron yellow	6. Safrangelb	6. jaune safran
7. green	7. Grün	7. vert
8. blue	8. Blau	8. bleu
9. bordeaux	9. Bordeaux	9. bordeaux
METAL FINISH	METALL AUSFÜHRUNG	FINITION MÉTAL
10. copper	10. Kupfer	10. cuivre
11. brass	11. Messing	11. laiton
12. pickled	12. Stahlgrau	12. décapé

DIMENSIONI / DIMENSIONS / GRÖßEN / DIMENSIONS

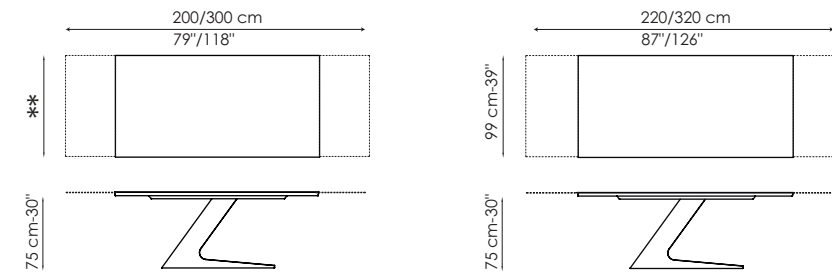

** 99 cm - 39"
legno, cristallo / wood, glass / Holz, Glas / bois, cristal
100 cm - 39.4"
ceramica / ceramic / Keramik / céramique

* prolunga disponibile anche in cristallo
* extension also available in glass
* Verlängerung verfügbar auch auf Glas
* rallonge disponible aussi en cristal

TOM



①

FINITURA PIANO E PROLUNGHE / TOP AND EXTENSIONS FINISH / PLATTE UND VERLÄNGERUNGEN AUSFÜHRUNG / FINITION PLAN ET RALLONGES

CRISTALLO

- 1. trasparente
- 2. nero fumè
- 3. extrachiaro vernic. bianco

GLASS

- 1. transparent glass
- 2. smoked black glass
- 3. extra-light glass painted white

GLAS

- 1. Klarglas
- 2. Rauchschwarz Glas
- 3. Glas extra-hell Weiss lackiert

CRISTAL

- 1. cristal transparent
- 2. cristal noir fumè
- 3. cristal extra-clair verni blanc

DIMENSIONI / DIMENSIONS / GRÖßEN / DIMENSIONS

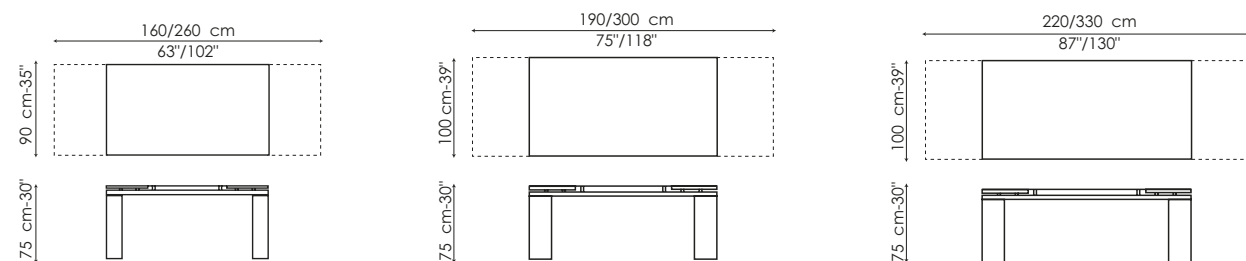

TRACKS

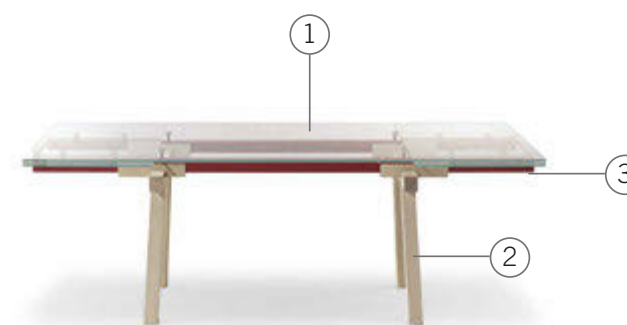

①

FINITURA PIANO E PROLUNGHE / TOP AND EXTENSIONS FINISH / PLATTE UND VERLÄNGERUNGEN AUSFÜHRUNG / FINITION PLAN ET RALLONGES

CRISTALLO

- 1. trasparente
- 2. trasparente extrachiaro

GLASS

- 1. transparent
- 2. extra-light transparent

GLAS

- 1. Klarglas
- 2. Klarglas extra-hell

CRISTAL

- 1. transparent
- 2. transparent extra-clair

③

FINITURA STRUTTURA / FRAME FINISH / STRUKTUR AUSFÜHRUNG / FINITION STRUCTURE

VERNICIATO OPACO

- 1. bianco
- 2. nero
- 3. grigio antracite
- 4. rosso
- 5. tortora
- 6. marrone

- 7. giallo zafferano
- 8. verde
- 9. blu
- 10. verde menta
- 11. bordeaux

MAT PAINTED

- 1. white
- 2. black
- 3. anthracite grey
- 4. red
- 5. dove grey
- 6. brown
- 7. saffron yellow
- 8. green
- 9. blue
- 10. mint green
- 11. bordeaux

LACKIERT MATT

- 1. Weiss
- 2. Schwarz
- 3. Anthrazitgrau
- 4. Rot
- 5. Taubengrau
- 6. Braun
- 7. Safrangelb
- 8. Grün
- 9. Blau
- 10. Minzgrün
- 11. Bordeaux

VERNI OPAQUE

- 1. blanc
- 2. noir
- 3. gris anthracite
- 4. rouge
- 5. gris tourterelle
- 6. marron
- 7. jaune safran
- 8. vert
- 9. bleu
- 10. vert menthe
- 11. bordeaux

②

FINITURA GAMBE / LEGS FINISH / BEINE AUSFÜHRUNG / FINITION PIEDS

LEGNO MASSELLO

- 1. frassino spazzolato naturale
- 2. frassino spazzolato grigio
- 3. noce americano (no spazzolato)

SOLID WOOD

- 1. natural polished ash
- 2. grey polished ash
- 3. american walnut (not polished)

MASSIVHOLZ

- 1. Eschenholz Natur poliert
- 2. Eschenholz Grau poliert
- 3. Amerikaner Nussbaum (nicht poliert)

BOIS MASSIF

- 1. frêne naturel brossé
- 2. frêne gris brossé
- 3. américain noyer (pas brossé)

DIMENSIONI / DIMENSIONS / GRÖßEN / DIMENSIONS

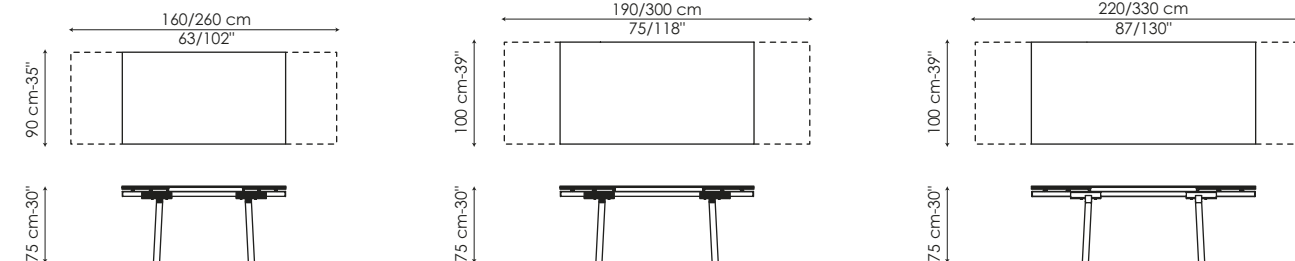

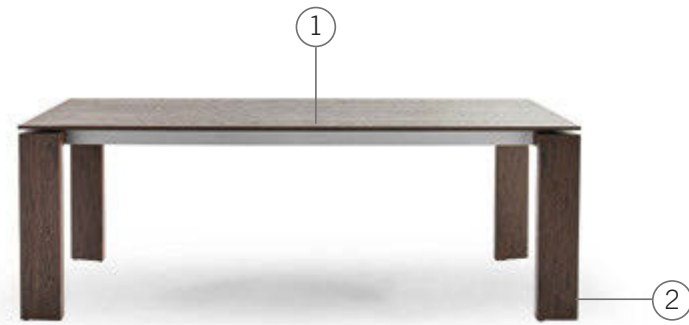
TWICE FISSO / FIXED / FEST / FIXE

①

FINITURA PIANO / TOP FINISH / PLATTE AUSFÜHRUNG / FINITION PLAN**CRISTALLO**

- | | | |
|-------------------------------|---------------------------|---|
| 1. extrachiaro vernic. bianco | 2. cristallo acidato nero | 3. cristallo extrachiaro acidato bianco |
|-------------------------------|---------------------------|---|

LEGNO IMPIALLACCIATO

- | | |
|-------------------|------------------------------------|
| 4. noce Canaletto | 5. rovere spazzolato termotrattato |
|-------------------|------------------------------------|

GLASS

- extra-light glass painted white
- acid treated black glass
- extra-light glass acid treated white

VENEERED WOOD

- Canaletto walnut
- heat-treated polished oak

GLAS

- Glas extra-hell Weiss lackiert
- Geätztes glas Schwarz
- Geätztes glas extra-hell Weiss

HOLZ FURNIERT

- Nussbaum Canaletto
- thermo-behandelte polierte Eiche

CRISTAL

- cristal extra-clair verni blanc
- cristal extra-clair verni sable
- cristal extra-clair traité à l'acide blanc

BOIS PLAQUÉ

- noyer Canaletto
- rouvre brossé traité thermiquement

②

FINITURA GAMBE / LEGS FINISH / BEINE AUSFÜHRUNG / FINITION PIEDS**IMPIALLACCIATO LEGNO**

- | | |
|-------------------|------------------------------------|
| 1. noce Canaletto | 2. rovere spazzolato termotrattato |
|-------------------|------------------------------------|

LACCATO

- | | |
|-----------------|------------------|
| 3. bianco opaco | 4. bianco lucido |
|-----------------|------------------|

VENEERED WOOD

- Canaletto walnut
- heat-treated polished oak

LACQUERED

- mat white
- glossy white

HOLZ FURNIERT

- Nussbaum Canaletto
- thermo-behandelte polierte Eiche

LACKIERT

- Weiss matt
- Weiss glänzend

BOIS PLAQUÉ

- noyer Canaletto
- rouvre brossé traité thermiquement

LAQUÉ

- blanc opaque
- blanc brillant

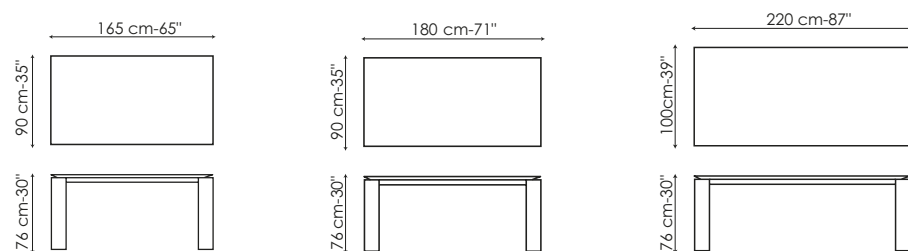
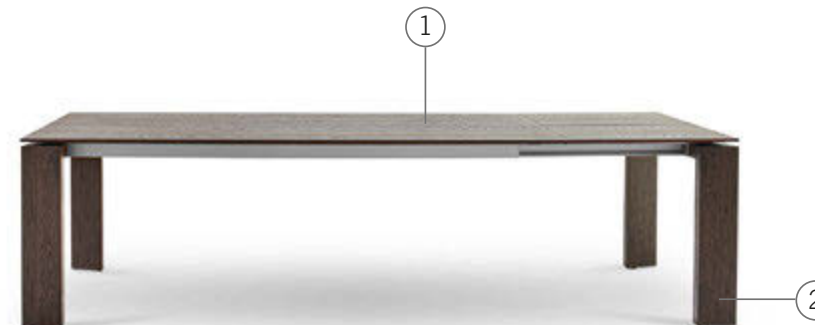
DIMENSIONI / DIMENSIONS / GRÖßEN / DIMENSIONS**TWICE ALLUNGABILE / EXTENDABLE / AUSZIEHBAR / EXTENSIBLE**

①

FINITURA PIANO / TOP FINISH / PLATTE AUSFÜHRUNG / FINITION PLAN**CRISTALLO**

- | | | |
|-------------------------------|---------------------------|---|
| 1. extrachiaro vernic. bianco | 2. cristallo acidato nero | 3. cristallo extrachiaro acidato bianco |
|-------------------------------|---------------------------|---|

LEGNO IMPIALLACCIATO

- | |
|------------------------------------|
| 4. rovere spazzolato termotrattato |
|------------------------------------|

GLASS

- extra-light glass painted white
- acid treated black glass
- extra-light glass acid treated white

VENEERED WOOD

- heat-treated polished oak

GLAS

- Glas extra-hell Weiss lackiert
- Geätztes glas Schwarz
- Geätztes glas extra-hell Weiss

HOLZ FURNIERT

- thermo-behandelte polierte Eiche

CRISTAL

- cristal extra-clair verni blanc
- cristal extra-clair verni sable
- cristal extra-clair traité à l'acide blanc

BOIS PLAQUÉ

- rouvre brossé traité thermiquement

②

FINITURA GAMBE E PROLUNGA / LEGS AND EXTENSION FINISH / BEINE UND VERLÄNGERUNGEN AUSFÜHRUNG / FINITION PIEDS ET RALLONGE**IMPIALLACCIATO LEGNO**

- | | |
|-------------------|------------------------------------|
| 1. noce Canaletto | 2. rovere spazzolato termotrattato |
|-------------------|------------------------------------|

LACCATO

- | | |
|-----------------|--|
| 3. bianco opaco | 4. bianco lucido (prolunga bianco opaco) |
|-----------------|--|

VENEERED WOOD

- Canaletto walnut
- heat-treated polished oak

LACQUERED

- mat white
- glossy white (mat white extension)

HOLZ FURNIERT

- Nussbaum Canaletto
- thermo-behandelte polierte Eiche

LACKIERT

- Weiss matt
- Weiss glänzend (Verlängerung Weiss matt)

BOIS PLAQUÉ

- noyer Canaletto
- rouvre brossé traité thermiquement

LAQUÉ

- blanc opaque
- blanc brillant (rallonge blanche opaque)

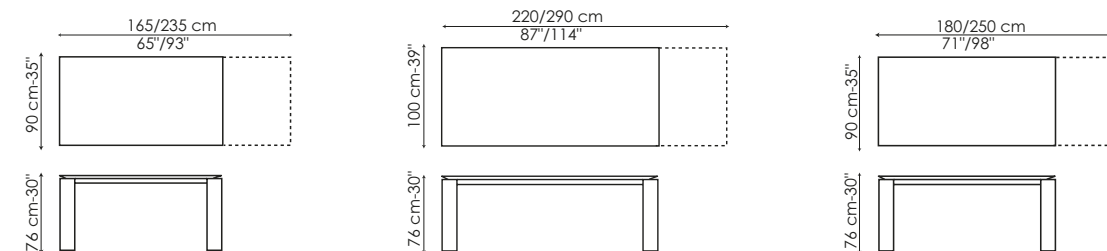
DIMENSIONI / DIMENSIONS / GRÖßEN / DIMENSIONS

VANESSA



①

FINITURA PIANO / TOP FINISH / PLATTE AUSFÜHRUNG / FINITION PLAN

CRISTALLO

1. cristallo trasparente

GLASS

1. transparent glass

GLAS

1. Klarglas

CRISTAL

1. cristal transparent

DIMENSIONI / DIMENSIONS / GRÖßEN / DIMENSIONS

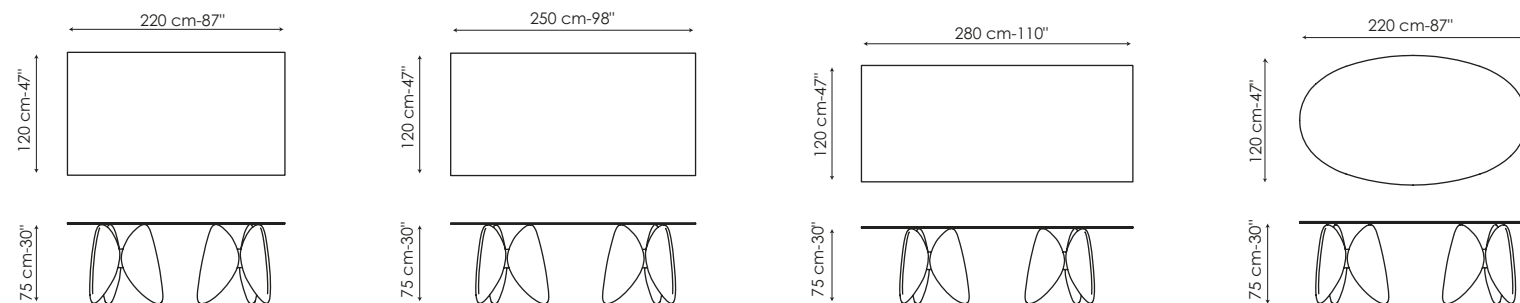

WELDED

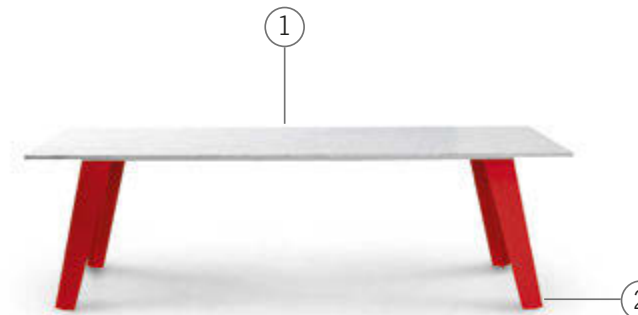

①

FINITURA PIANO / TOP FINISH / PLATTE AUSFÜHRUNG / FINITION PLAN

LACCATO OPACO

1. bianco opaco

IMPIALLACCIATO LEGNO

6. noce canaletto

7. rovere spazz. termotrattato

CRISTALLO

9. acidato nero

10. extrachiaro acidato bianco

11. acidato grigio antracite

MARMO
non disponibile per 300 cm

12. Carrara bianco opaco

CERAMICA OPACA

13. bianco iridium

14. grigio grafite

CERAMICA LUCIDA

15. Calacatta

16. Paonazzetto

②

FINITURA GAMBE / LEGS FINISH / BEINE AUSFÜHRUNG / FINITION PIEDS

VERNICIATO OPACO

1. bianco

2. grigio antracite

3. rosso brillante

4. arancio

5. verde

6. marrone

DIMENSIONI / DIMENSIONS / GRÖßEN / DIMENSIONS

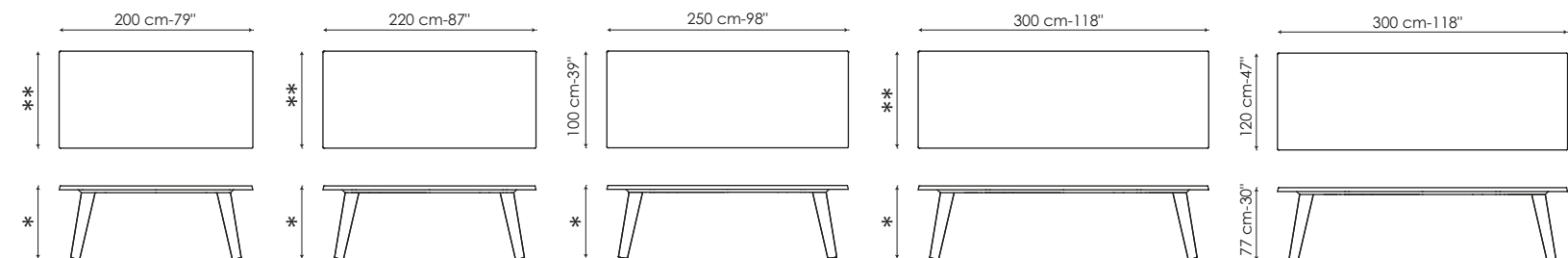

** 100 cm – 39.4"
legno, ceramica, marmo / wood, ceramic, marble / Holz, Keramik, Marmor / bois, céramique, marbre

99 cm – 39"
cristallo / glass / Glas / cristal

75.50 cm – 29.7"
laccato, impiallacciato, cristallo, ceramica / lacquered, veneered, glass, ceramic / lackiert, furniert, Glas, Keramik / laqué, plaqué, cristal, céramique

77 cm – 30.3"
massello, legno con bordi naturali / solid, wood with natural edges / Massivholz, Holz mit Waldkante / massif, bois avec contour naturel

76 cm – 29.9"
marmo / marble / Marmor / marbre

** 100 cm – 39.4"
massello, impiallacciato, laccato, cristallo, ceramica, marmo / solid, veneered, lacquered, glass, ceramic, marble / Massivholz, furniert, lackiert, Glas, Keramik, Marmor / massif, plaqué, laqué, cristal, céramique, marbre

110 cm – 43.3"
legno con bordi naturali / wood with natural edges / Holz mit Waldkante / bois avec contour naturel

* 75.50 cm – 29.7"
laccato, impiallacciato, cristallo, ceramica / lacquered, veneered, glass, ceramic / lackiert, furniert, Glas, Keramik / laqué, plaqué, cristal, céramique

77 cm – 30.3"
massello, legno con bordi naturali / solid, wood with natural edges / Massivholz, Holz mit Waldkante / massif, bois avec contour naturel

76 cm – 29.9"
marmo / marble / Marmor / marbre

MAT LACQUERED

1. white

SOLID WOOD

2. American walnut
3. walnut 400
4. natural polished oak
5. anthracite grey polished oak

VENEERED WOOD

6. walnut canaletto
7. heat-treated polished oak

WOOD WITH NATURAL EDGES

8. American walnut

GLASS

9. acid-treated black
10. extra-light acid treated white
11. acid-treated anthracite

MARBLE

not available for 300 cm
12. mat white Carrara

MAT CERAMIC

13. white iridium
14. graphite grey

GLOSSY CERAMIC

15. Calacatta
16. Paonazzetto

MATT LACKIERT

1. Weiss

MASSIVHOLZ

2. Amerikaner Nussbaum
3. Nussbaum 400
4. Eiche Natur poliert
5. Eiche Anthrazitgrau poliert

HOLZ FURNIERT

6. Nussbaum Canaletto
7. thermo-behandelte polierte Eiche

HOLZ MIT WALDKANTE

8. Amerikaner Nussbaum

GLAS

9. Geätztes Schwarz
10. Geätztes extra-hell Weiss
11. Geätztes Anthrazitgrau

MARMOR

nicht verfügbar für 300 cm
12. Weiss matt Carrara

MATT KERAMIC

13. Weiss Iridium
14. Graphitgrau

GLÄNZEND KERAMIC

15. Calacatta
16. Paonazzetto

LAQUÉ OPAQUE

1. opaque

BOIS MASSIF

2. noyer américain
3. noyer 400
4. rouvre brossé naturel
5. rouvre brossé gris anthracite

BOIS PLAQUÉ

6. noyer canaletto
7. rouvre brossé traité thermiquement

BOIS AVEC CONTOUR NATUREL

8. noyer américain

CRISTAL

9. traité à l'acide noir
10. extra-clair traité à l'acide blanc
11. traité à l'acide gris anthracite

MARBRE

pas disponible pour 300 cm
12. blanc opaque Carrara

CÉRAMIQUE OPAQUE

13. blanc iridium
14. gris graphite

CÉRAMIQUE BRILLANT

15. Calacatta
16. Paonazzetto

MAT PAINTED

1. white
2. anthracite grey
3. luminous red
4. orange
5. green
6. brown

LACKIERT MATT

1. Weiss
2. Anthrazitgrau
3. Leuchttrot
4. Orange
5. Grün
6. Braun

VERNI OPAQUE

1. blanc
2. gris anthracite
3. rouge brillant
4. orange
5. vert
6. marron

Legno / Wood / Holz / Bois



noce americano
American walnut
Amerikaner Nussbaum
noyer américain

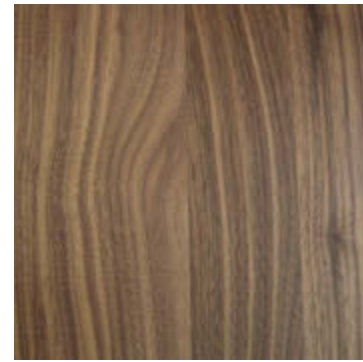

noce 400
400 walnut
Nussbaum 400
noyer 400



noce canaletto
canaletto walnut
Nussbaumholz Canaletto
noyer canaletto



rovere spazzolato naturale
natural polished oak
Eiche Natur poliert
rouvre brossé naturel



rovere con nodi spazzolato naturale
natural polished oak with knots
Eiche mit Knoten Natur poliert
rouvre avec noeuds brossé naturel



rovere spazzolato termotrattato
heat-treated polished oak
thermo-behandelte polierte Eiche
rouvre brossé thermiquement



rovere spazzolato grigio antracite
anthracite grey polished oak
Eiche Anthrazitgrau poliert
rouvre brossé gris anthracite



frassino spazzolato bianco
white polished ash
Eschen Weiss poliert
frêne brossé blanc



frassino spazzolato naturale
natural polished ash
Eschen Natur poliert
frêne naturel brossé



frassino tinto noce
walnut painted ash
Eschen nussbaumfarbig lackiert
frêne teinté noyer



frassino spazzolato grigio
grey polished ash
Eschen Grau poliert
frêne brossé gris

Legno Laccato / Lacquered Wood / Holz Lackiert / Bois Laqué

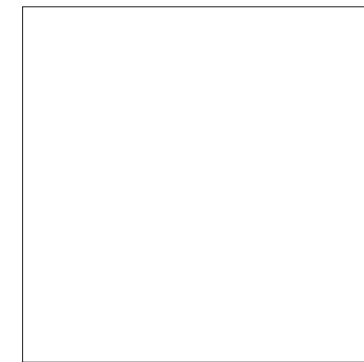

bianco lucido
glossy white
Weiss glänzend
blanc brillant

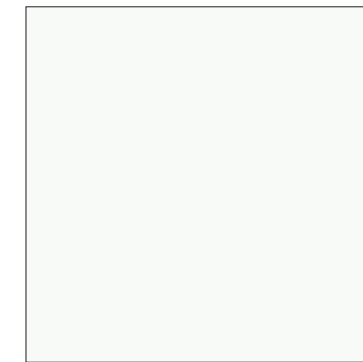

bianco opaco
matt white
Weiss matt
blanc opaque

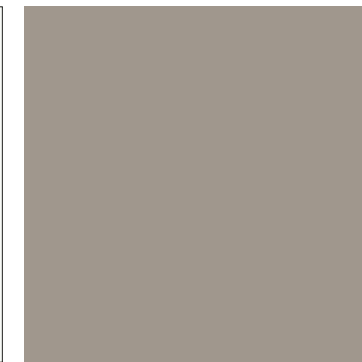

tortora opaco
matt dove grey
Taubengrau matt
gris tourterelle opaque



grigio antracite opaco
matt anthracite grey
Anthrazitgrau matt
gris anthracite opaque

Doluflex®

Pannello strutturale in alluminio ultraleggero / Structural panel in ultra-light aluminium / Strukturplatte aus superleichtem Aluminium / Panneau structurel en aluminium ultraléger

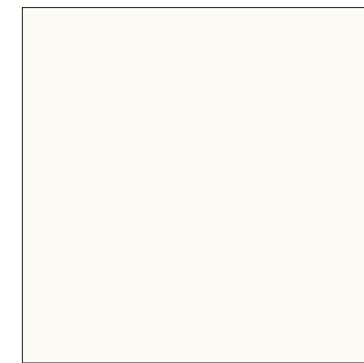

laminato bianco
white laminated
Laminat weiss
laminé blanc



laminato grigio antracite
anthracite grey laminated
Laminat anthrazitgrau
laminé gris anthracite

Marmo / Marble / Marmor / Marbre

disponibile nella finitura opaca o lucida / available mat or glossy / matt oder glänzend erhältlich / disponible opaque ou brillant



marmo di Carrara
Carrara marble
Carrarischer Marmor
marbre de Carrara



marmo Calacatta
Calacatta marble
Calacatta Marmor
marbre Calacatta



marmo Emperador
Emperador marble
Emperador Marmor
marbre Emperador

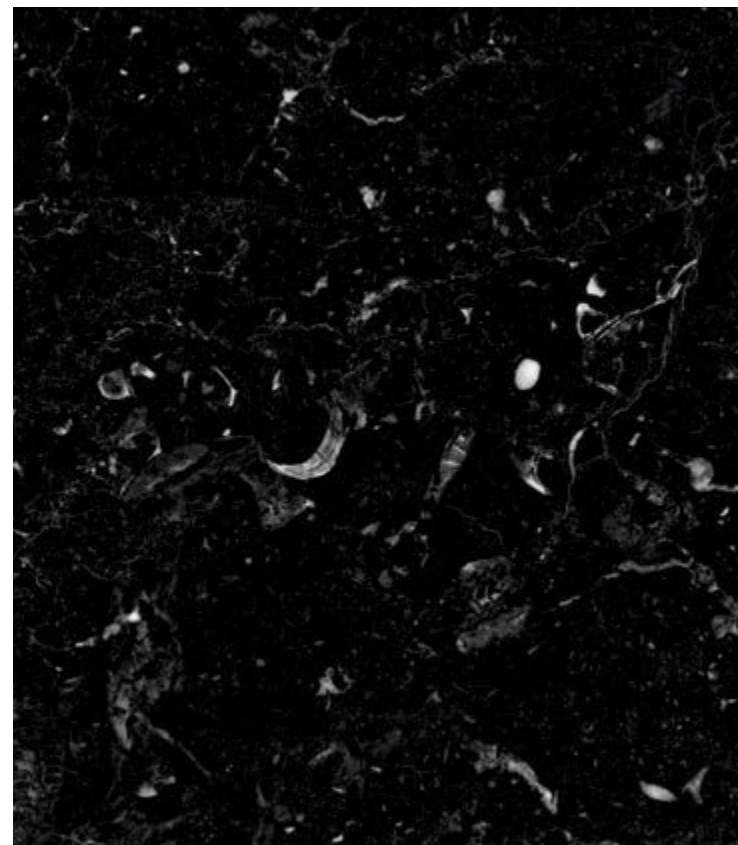

marmo Marquinia
Marquinia marble
Marquinia Marmor
marbre Marquinia

Ceramica / Ceramic / Keramik / Céramique



ceramica bianco iridium
white ceramic
Weiss Keramik
céramique blanche



ceramica grigio antracite
anthracite grey ceramic
Anthrazitgrau Keramik
céramique gris anthracite



ceramica Calacatta
Calacatta ceramic
Calacatta Keramik
céramique Calacatta



ceramica Paonazetto
Paonazetto ceramic
Paonazetto Keramik
céramique Paonazetto

Pietra / Stone / Stein / Pierre

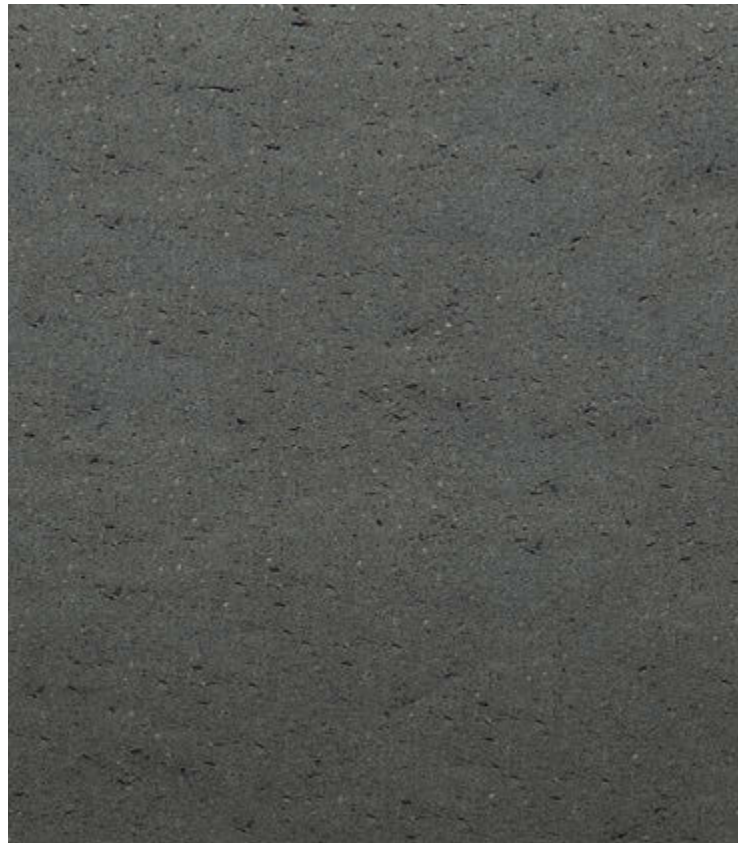

pietra basaltina
basaltina stone
Stein Basaltina
pierre basaltina

Cristallo / Glass / Glas / Cristal

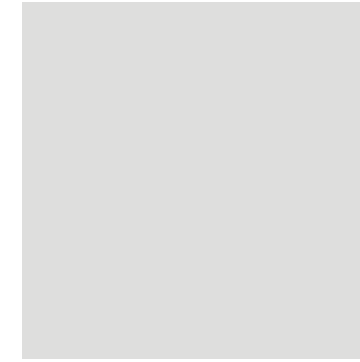

cristallo extrachiaro trasparente
extra-light transparent glass
Klarglas extra-hell
cristal extra-clair transparent



cristallo trasparente
transparent glass
Klarglas
cristal transparent



cristallo extrachiaro acidato bianco
white acid-treated extra-light glass
Geätztes Glas extra-hell Weiss
cristal extra-clair traité à l'acide blanc



cristallo extrachiaro verniciato bianco
white painted extra-light glass
Glas extra-hell Weiss lackiert
cristal extra-clair verni blanc



cristallo extrachiaro acidato tortora
dove grey acid-treated extra-light glass
Geätztes Glas extra-hell Taubengrau
cristal extra-clair traité à l'acide gris
tourterelle



cristallo nero fumè
smoked black glass
Rauchschwarz Glas
cristal noir fumé



cristallo acidato grigio antracite
anthracite grey acid-treated glass
Geätztes Anthrazitgrau Glas
cristal traité à l'acide gris anthracite



cristallo acidato nero
black acid-treated glass
Geätztes Schwarz Glas
cristal traité à l'acide noir



cristallo verniciato nero
black painted glass
Glas Schwarz lackiert
cristal verni noir

Metalli / Metals / Metalle / Métaux

verniciati / painted / Lackiert / vernis

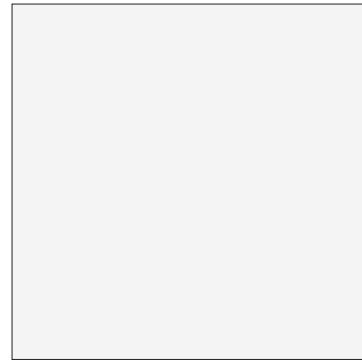

bianco lucido
glossy white
Weiss glänzend
blanc brillant

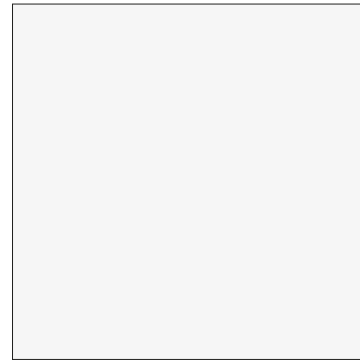

bianco opaco
mat white
Weiss matt
blanc opaque



argento opaco
mat silver
Silber matt
argent opaque



tortora opaco
mat dove grey
Taubengrau matt
gris tourterelle opaque



azzurro artico opaco
mat arctic blue
Arktisch blau matt
bleu artique opaque



blu opaco
mat blue
Blau matt
bleu opaque



verde menta opaco
mat mint green
Minzgrün matt
vert menthe opaque



verde opaco
mat green
Grün matt
vert opaque

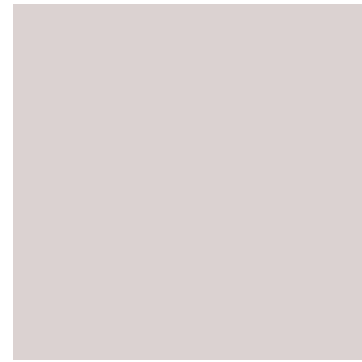

rosa cipria opaco
mat powered pink
Pudderosa matt
rose poudré opaque



lilla opaco
mat lilac
Lila matt
lilas opaque



giallo zafferano opaco
mat saffron yellow
Safrangelb matt
jaune safran opaque



arancio opaco
mat orange
Orange matt
orange opaque



racing green opaco
mat racing green
Racing green matt
racing green opaque



grigio antracite opaco
mat anthracite grey
Anthrazitgrau matt
gris anthracite opaque



nero opaco
mat black
Schwarz matt
noir opaque

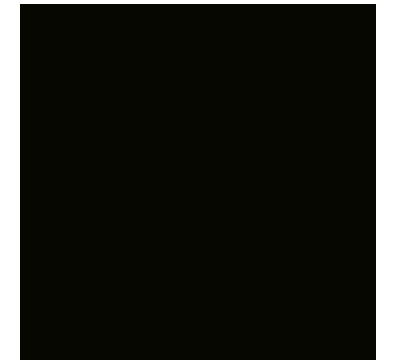

nero lucido
glossy black
Schwarz glänzend
noir brillant



mattone opaco
mat brick red
Ziegelrot matt
brique opaque



rosso brillante opaco
mat luminous red
Leuchtrot matt
rouge brillant opaque



rosso corallo opaco
mat coral red
Korallenrot matt
rouge corail opaque



rosso opaco
mat red
Rot matt
rouge opaque



bordeaux opaco
mat bordeaux
Bordeaux matt
bordeaux opaque

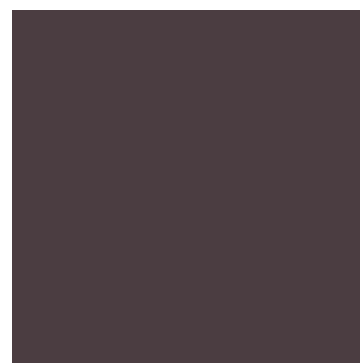

amaranto opaco
mat amaranth
Amaranth matt
amarante opaque

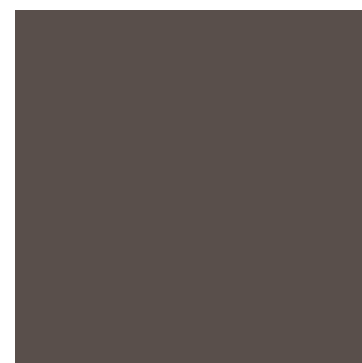

marrone opaco
mat brown
Braun matt
marron opaque



coffee brown opaco
mat coffee brown
coffee brown matt
coffee brown opaque

Metalli / Metals / Metalle / Métaux

finiture / finishes / Ausführung / finitions

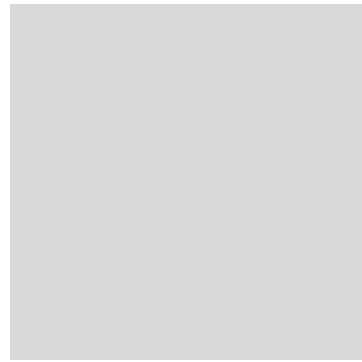

alluminio spazzolato
polished aluminium
Aluminium poliert
aluminium brossé

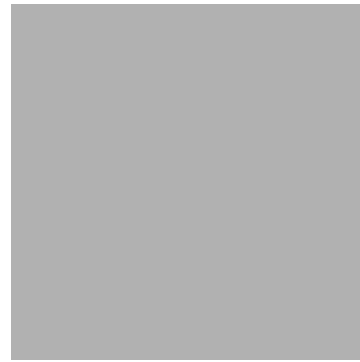

alluminio anodizzato argento
anodized silver aluminium
Anodisiert Silber Aluminium
aluminium anodisé argent

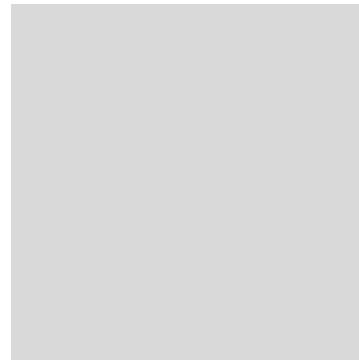

cromato
chromed
Verchromt
chromé



acciaio inox
stainless steel
Edelstahl
acier inox

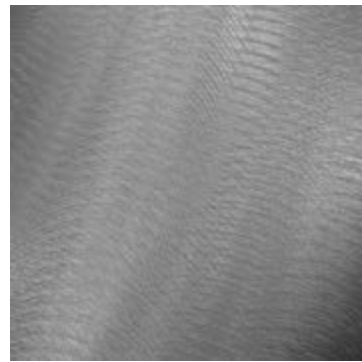

acciaio spazzolato
polished steel
Stahl poliert
acier brossé

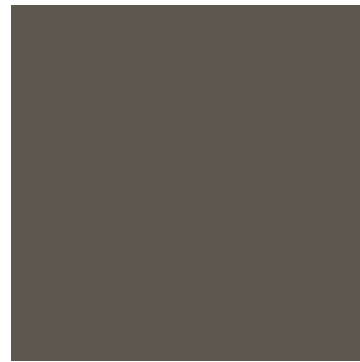

black nickel
black nickel
Schwarz vernikelt
noir nickel

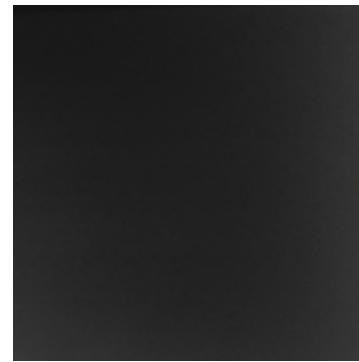

alluminio anodizzato nero
anodized black aluminium
Anodisiert Schwarz Aluminium
aluminium anodisé noir



finitura brunito
burnished finish
Brüniert Ausführung
finition bruni



finitura decapato
pickled finish
Stahlgrau Ausführung
finition décapé



Corten
Corten
Corten
Corten



finitura rame
copper finish
Kupfer Ausführung
finition cuivre



finitura rame opaco
mat copper finish
Kupfer matt Ausführung
finition cuivre opaque



finitura bronzo-rame
copper-bronze finish
Kupferbronze Ausführung
finition bronze-cuivre



finitura ottone
brass finish
Messing Ausführung
finition laiton



finitura ottone opaco
mat brass finish
Messing matt Ausführung
finition laiton opaque

concept
romanoassociati.com

press
Grafiche Antiga

Printed in Italy
November 2016

We are social



Bonaldo SpA si riserva di modificare, senza preavviso, materiali, rivestimenti, finiture e disegni dei prodotti presentati in questo catalogo.

I colori e le finiture visualizzate sono puramente indicativi e possono differire dagli originali. Le immagini riprodotte nel presente catalogo sono di proprietà esclusiva di Bonaldo SpA.

È vietata qualunque riproduzione o utilizzo delle immagini senza preventiva autorizzazione scritta di Bonaldo SpA.

Bonaldo SpA reserves the right to change, without any notice, materials, covers, finishes and drawings of the products presented in this catalogue.

Colors and finishes shown are approximate and may differ from actual ones. All images in this catalogue are exclusive property of Bonaldo SpA.

Every reproduction or use of the images without prior written authorization from Bonaldo SpA is therefore strictly forbidden.

Bonaldo SpA behält sich das Recht vor, ohne vorherige Ankuendigung, Materialien, Ersatzbezeuge, Ausfuehrungen und Zeichnungen der in diesem Katalog vorgestellten Produkte zu aendern.

Die dargestellten Farben und Ausfuehrungen sind ungefaehre Angaben und koennen von den Originalen abweichen.

Die in diesem Katalog abgebildete Bilder sind ausschliesslich Eigentum von Bonaldo SpA.

Ohne die vorherige schriftliche Genehmigung von Bonaldo SpA ist es jede Vervielfaeltigung oder Verwendung von Bildern verboten.

Bonaldo SpA se réserve le droit de modifier, sans préavis, les matériaux, les revêtements, les finitions et les dessins des produits présentés dans ce catalogue.

Les couleurs et les finitions indiquées sont indicatives et peuvent différer des originaux. Les images reproduites dans ce catalogue sont propriété exclusive de Bonaldo SpA

Il est interdit la reproduction ou utilisation d'images sans l'autorisation écrite préalable de Bonaldo SpA.

BONALDO

Bonaldo SpA _ via Straelle, 3 35010 Villanova di Camposampiero (PD) Italy tel + 39 049.9299.011 bonaldo@bonaldo.it www.bonaldo.it